

RISE® MULTI-CABLE TRANSITS: RAPID SEALING SYSTEM ACTIVE FIRE STOP GAS- AND WATERTIGHT



**SUCCESSFULLY TESTED ACCORDING TO
EN 1366-3:2004; FIRE RESISTANCE
EI120/E240 ACCORDING TO EN 13501-2:2003
CERTIFICATE 2007-EFECTIS-R0157**





**MAXIMUM SIMPLICITY OF USE
OPTIMUM FLEXIBILITY
OUTSTANDING PERFORMANCE**

Websites: <http://www.actifoam.com>, www.beele.com, www.firsto.com, www.nofirno.com,
www.rise-systems.com, www.rise-nofirno.com, www.riswat.com and www.slipsil.com

- Copyright** : BEELE Engineering BV/CSD International BV, Aalten, the Netherlands.
Proprietary rights on all drawings and technical data released in this brochure.
© 1997-2009
- Edition** : February 2009
- Note** : No part of this publication may be reproduced without explicit written approval of
BEELE Engineering BV.
- Research & Development** : BEELE Engineering BV, Aalten, the Netherlands.
- Note** : The manufacturer reserves the right to make dimensional and design modifications
without prior notification.
- ® : ACTIFIRE, ACTIFOAM, AQUASTOP, BEEBLOCK, BEELE, BEESEAL, CONDUCTON,
CRUSHER, CSD, CSD THE SIMPLE SEAL SYSTEM, DRIFIL, DYNATITE, FIRSO,
FIRUB/NOHAL, FITEFIRE, FIWA, FRR, LEAXEAL, LUMIREFLEC, MULTI-ALL-MIX,
NOFIRNO, RAPID TRANSIT SYSTEM, RIACNOF, RISE, RISWAT, S, SLIPSIL,
flanges SLIPSIL plugs, ULEPSI and YFESTOS are registered trade marks of
BEELE Engineering BV.
- brochure code** : RISEcable/hb/en/con



BEELE ENGINEERING BY CSD INTERNATIONAL BV

BEELE Engineering and CSD International have been working in the field of water and gas tight and fireproof sealing of conduits for pipes and cables for more than 30 years. In the field of passive fire prevention, we have invested substantial amounts of money in the development of systems which are capable withstanding fires for extended periods of time. Passive fire prevention is a very complicated matter due to the fact that cable and pipe penetrations have to be designed to the actual circumstances at site and not for a laboratory test. In case of a catastrophe penetrations are subject not only to flame erosion and very high temperatures, but also

to mechanical loads due to collapsing cableways and possibly a jet of fire-fighting water. This means that the performance in actual situations can differ dramatically from that in a regular fire test. In fact, the systems could only be applied as tested to guarantee the required fire safety.

And this means discussions and limitations!

We have ensured that our systems will function under all circumstances, and the classification societies have awarded us signed and stamped installation drawings of our sealing systems. Approved for steel and aluminium partitions. Guaranteed safety in your installation will be the result.

The R&D department of BEELE Engineering is constantly working in the field of rubber and systems techniques to optimize the existing systems and to develop new concepts for cable and pipe conduits on board of vessels and offshore installations. Although installation of the CSD sealing systems is in fact an easy matter, a full training programme can be given in-house by our engineers. Because the advantages and possibilities of passive fire prevention and evacuation signposting can most effectively be discovered in an environment that matches the practical situation as closely as possible, we have constructed an unique research and development centre. As far is known, this R&D centre is the only institute world-wide where visitors can experience for themselves all the aspects of fire prevention and evacuation signposting systems.



Above an impression of the research and development centre with a training and schooling institute for passive fire prevention products and systems and for the improvement of evacuation signposting systems in buildings and on board ships. The centre consists of a presentation theatre seating up to 45 persons, and a mock-up covering about 500 square metres in which various evacuation signposting systems are installed to enable their effectiveness to be

determined in the dark.

The behaviour of escaping persons inside the test facility are recorded from a separate technical area (with an associated showroom) by means of infra-red cameras and an audio-video system.

In addition the centre comprises three laboratories with a total surface area of about 300 square metres in which, respectively, large-scale fire tests, mechanical tests, and light emission investigations are performed.

RISE® MULTI-CABLE TRANSITS: THE RAPID® SEALING SYSTEM

*RISE® multi-cable penetrations:
based on high-tech ACTIFIRE® technology*

RISE® multi-cable penetrations are an alternative for the casting compounds and block systems used in fire-rated/watertight bulkheads and decks.

Very easy to install.

Time saving, space saving, weight saving.

The very limited amount of different parts makes this system easy to handle on site. Use is made of rubber inserts (placed around the cables) and filler sleeves. The FRR/LEHF (fire resistant rubber/low grade of expansion, halogen free) rubber of the sleeves expands 5-10 times its original volume when exposed to fire. On both sides of the penetration a layer of FIWA® sealant (fire resistant, water repellent) is applied.

Only halogen free components.

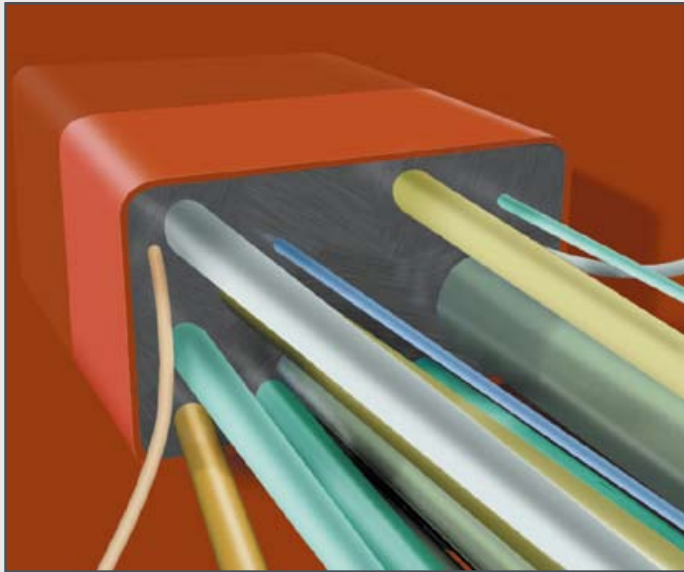

*RISE® multi-cable penetrations:
ultimate flexibility, maintenance friendly*



RISE® multi-cable penetrations offer a most simple way of installation. No precise positioning of the cables in the transit needed.

The RISE® sealing system allows cables to be ducted through conduit openings in a bent, curved or oblique way without any adverse impact on sealing performance.

The RISE® sealing system gives easy access to add or remove cables in a later stage without the necessity to disassemble the whole penetration. Just cut away a piece of the FIWA® layer at both sides of the penetration, pull the cable through and refill the opening in the sealant layer.

It is that simple!

RISE[®] MULTI-CABLE TRANSITS: THE RAPID[®] SEALING SYSTEM

*RISE[®] multi-cable penetrations:
based on high-tech ACTIFIRE[®] technology*

SYSTEM WILL BE ACTIVATED WHEN EXPOSED TO FIRE
ALL COMPONENTS ARE TOTALLY HALOGEN FREE
IN CASE OF FIRE: NON-TOXIC, LOW SMOKE INDEX
CE (MED) CERTIFICATES FOR A-0 UP TO A-60
CERTIFIED FOR H-0 UP TO H-120
APPROVED WATER TIGHT UP TO 2.5 BAR
APPROVED GAS TIGHT UP TO 1 BAR
CAN BE USED IN ARCTIC CONDITIONS
HIGH LEVEL OF EMC AND SOUND DAMPING
SHOCK AND VIBRATION PROOF
UP TO 50 YEARS SERVICE LIFE
CAPABLE OF ABSORBING TEMPERATURE CHANGES
WEATHERING, UV AND OZONE RESISTANT
NO PRE-ENGINEERING NEEDED
NO SPECIAL CONDUIT FRAMES
MINIMIZED NUMBER OF STRUCTURAL COMPONENTS
MOST COMPACT INSTALLATION
EXTREMELY SIMPLE TO INSTALL
NO INSULATION IN FRONT OF THE PENETRATION
SHORTEST POSSIBLE CONDUIT LENGTH
LESS OVERALL INSULATION NEEDED
CAN BE USED FOR CABLE AND PIPE ENTRIES
APPROVED FOR STEEL AND ALUMINIUM PARTITIONS
MAINTENANCE FRIENDLY

3



RISE[®] MULTI-CABLE TRANSITS: THE RAPID[®] SEALING SYSTEM

*no pre-engineering needed for a
RISE[®] multi-cable penetration*

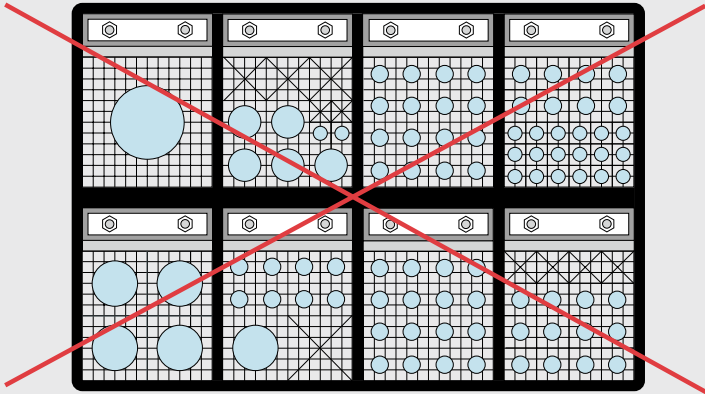

Since the cables can be ducted in random order through the conduit frame or sleeve it is not necessary to create lay-outs for the installers to be sure that the cables are ducted at the right spot in the conduit. We have a software program available for calculating the size of the conduit opening and the amount of insert sleeves and sealant for each RISE[®] penetration. All penetrations can be put in a database to calculate the total amount for a project (see page 35). Could it be easier?

*no time-consuming lay-outs for a
RISE[®] multi-cable penetration*

*no special conduit frames needed for a
RISE[®] multi-cable penetration*

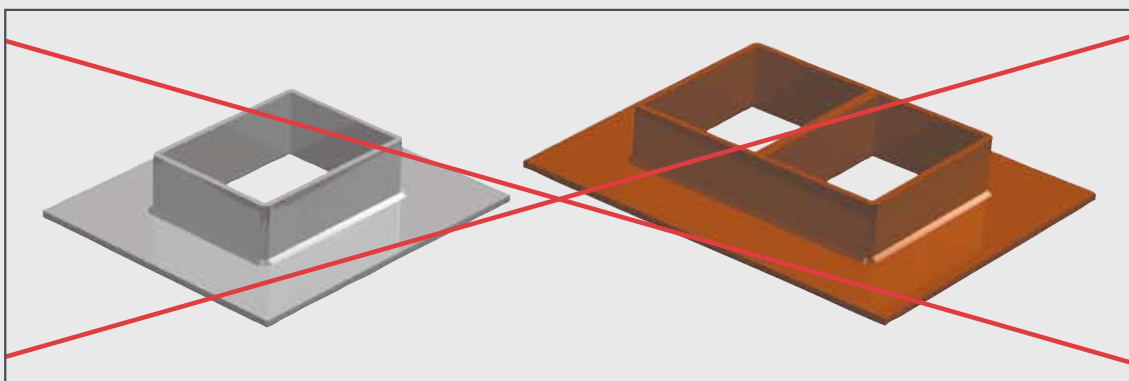

*whatever conduit sleeve you have around
will do for a RISE[®] multi-cable penetration*

RISE[®] MULTI-CABLE TRANSITS: THE RAPID[®] SEALING SYSTEM

*time-saving installation of
RISE[®] multi-cable penetrations*

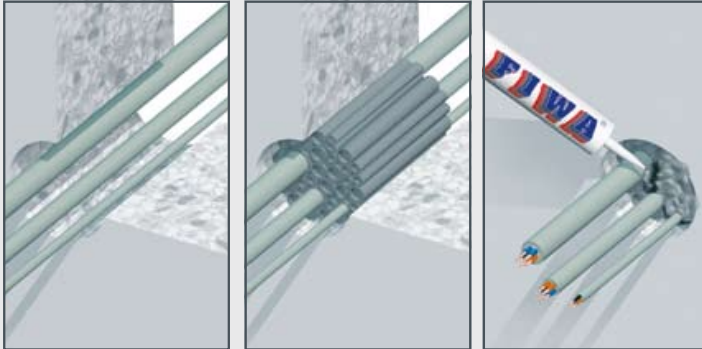

It's so simple. Just place the length-wise split insert sleeves around the cables, fill up any spare space with empty sleeves and seal it off on both sides. No work for specialists. What could be easier!

Calculate the right way, save time and money.

Ask for the installation video showing that a transit measuring 450x130 mm with 63 cables is sealed within 40 minutes.

Substantial cost-savings.

*no bolts, no nuts, no precise fitting work
with RISE[®] cable penetrations*

*space and weight saving properties of
RISE[®] multi-cable penetrations*

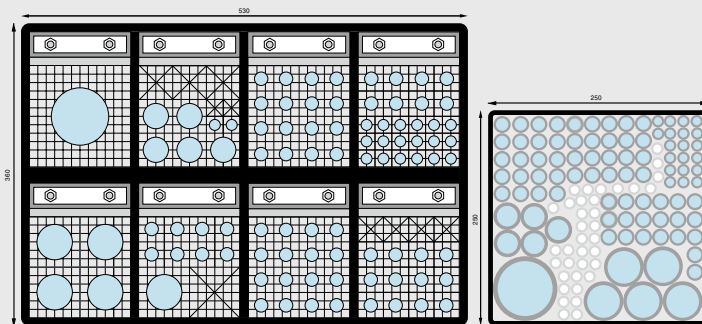

same amount of cables in less than half the conduit size with RISE[®]

Modular sealing systems are based on prefabricated rubber parts. A substantial separation if the cables might occur. Totally different with RISE[®]. The conduit opening can be substantially reduced, due to the high fill capacity of RISE[®].

Other than using solid rubbers as in modular systems, any spare space in the RISE[®] conduit is filled with hollow filler sleeves. The overall specific weight is therefore very low. Less weight is added to the penetration compared to filling with heavy solid rubber parts.

*substantial overall time-savings with
RISE[®] multi-cable penetrations*

RISE[®] MULTI-CABLE TRANSITS: THE RAPID[®] SEALING SYSTEM

*fire tested on full scale bulkhead and deck
in accordance with IMO Res. A.754(18)*



Generally, multi-cable transits have to be installed as tested. It will be clear that a transit tested with only a couple of small cables will not meet an A60 classification when fully packed with heavy conductor cables. RISE[®] multi-cable penetrations are tested with all types of cables, from communication to power cables with small dimensions, up to cables with a dimension of 85 mm, armoured and non-armoured, at full load and according to the latest IMO Resolution A.754(18).

*RISE[®] is successfully tested with a wide variety
of cable types and sizes up to 85 mm OD*

*RISE[®] is successfully tested with more than
100 cables to enable a high cable fill capacity*

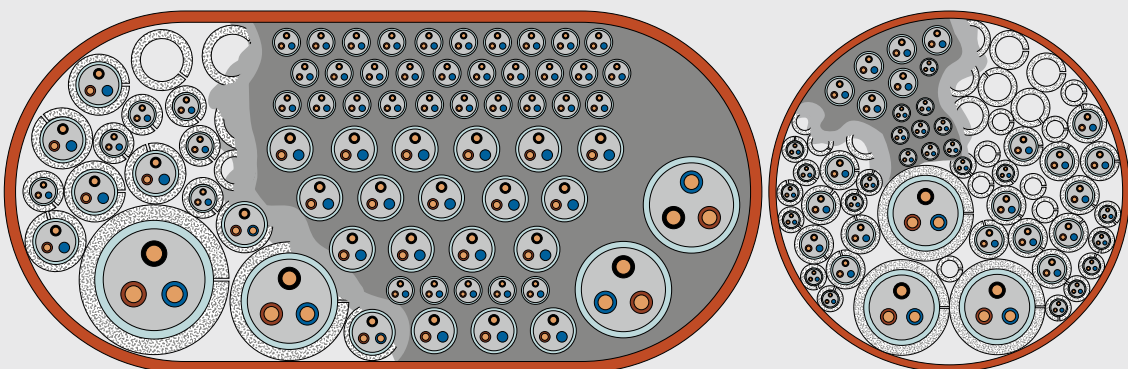

RISE[®] is designed to duct the maximum allowable filling rate of 40% as defined in the IMO Res. A.754(18).

*most compact installation ever with a
RISE[®] multi-cable penetration*

RISE® MULTI-CABLE TRANSITS: THE RAPID® SEALING SYSTEM

*fire tested with insulation at one side only
in accordance with IMO Res. A.754(18)*

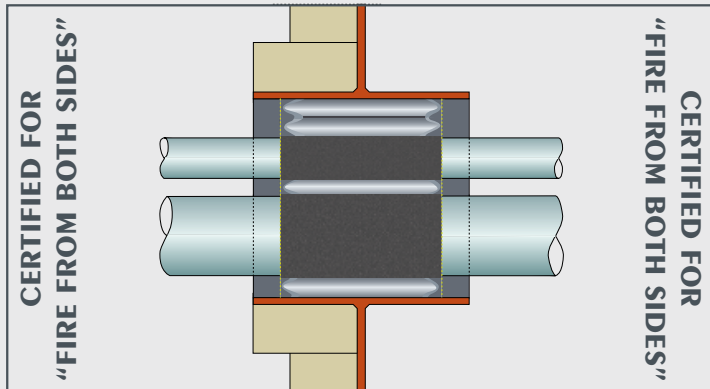

Section A.IV/2.2.1 of IMO Res. A.754(18) states "A bulkhead which includes the cable transit should be constructed in accordance with 2.1.1 of the recommendation and **should be insulated to class A-60 on the stiffened side, which should be the face which is not exposed to the heating conditions of the test.**" Systems tested with insulation at the exposed side have a limitation in the application. The bulkhead must then be totally insulated at both sides! This is not the case with RISE®.

*shortest possible conduit length, less
insulation with RISE® multi-cable penetrations*

*fire tested in worst case scenarios
in accordance with IMO Res. A.754(18)*

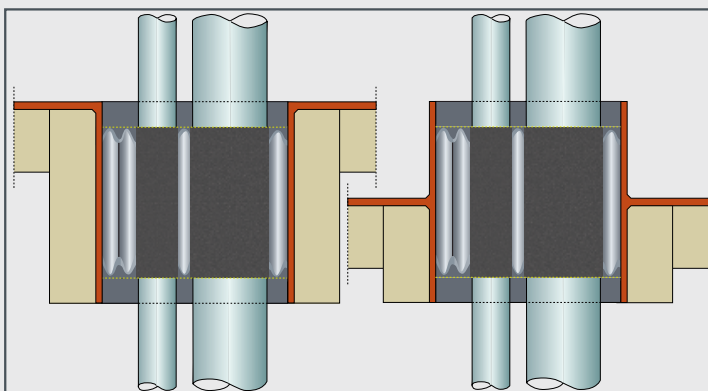

The easiest way to pass a deck test is to place the transit totally above deck. **Worst case for deck penetrations is to place the transits totally below deck.** And that is exactly the way the penetrations generally are installed! Cable penetrations should be applied as tested. This means that penetrations tested only above deck should not be placed totally below deck. RISE® multi-cable penetrations are tested "worst case" and can be welded in above, below, midway.

*any position of the transits will do for
a RISE® multi-cable penetration*

RISE[®] MULTI-CABLE TRANSITS: THE RAPID[®] SEALING SYSTEM

RISE[®] is based on ACTIFIRE[®] technology and will be activated when exposed to fire

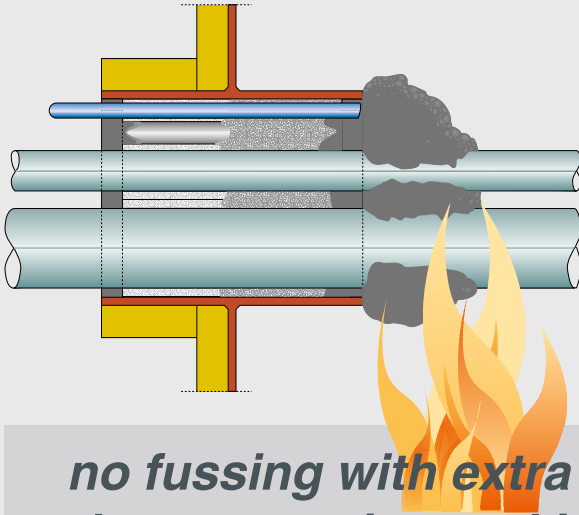

All classes above A-0 or H-0 must have a T-rating (not exceeding 180 °C/400 °F at the unexposed side). **For every technician it will be clear that when ducting cables containing a lot of copper, the length of the penetration is a determining factor here.** RISE[®] cable penetrations have been tested with heavy conductor cables. The length of the conduit could be minimized by the use of the expanding sealant/rubber, which lengthen the penetration when exposed to fire. For A-class penetrations the conduit sleeve/frame needs to be insulated only at the insulated side of the bulkhead or at the lower side of the deck.

no fussing with extra insulation in front of the penetration and in between the cables

RISE[®] materials expand massively when exposed to heat or flames



Generally, rubbers used for multi-cable transit systems are made of a more or less self-extinguishing compound. The drawback, however, is that these rubbers will start charring under heat and slowly but surely will shrink due to the loss of the water content in the rubber. **Not with RISE[®]!**

The rubber starts vulcanizing when exposed to heat, forming a solid rubber mass inside the penetration and an expanding char on all exposed surfaces.

all gaps will be filled automatically by the “self-correcting” RISE[®] cable penetration

RISE[®] MULTI-CABLE TRANSITS: THE RAPID[®] SEALING SYSTEM

*approved gas and water tight
RISE[®] multi-cable penetration*

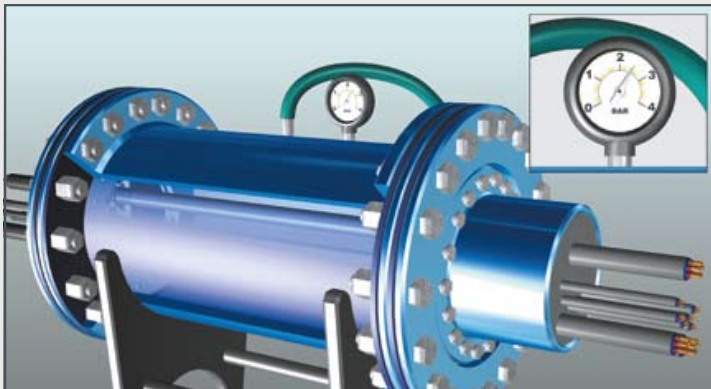

Due to the high bonding strength and flexibility of the FIWA[®] sealant, the penetrations could be subjected to certified pressures up to 2.5 bar (35 Psi) without any leakage. Where rubber parts have to be strongly compressed to obtain water tightness, they will soon show permanent deformation. Also, the cable sheathings are exposed to this heavy load and will creep. This is not the case with RISE[®]. **Tight stays tight, with no compressive forces on the cables! CERTIFIED.**

*no compression needed to obtain a watertight
RISE[®] multi-cable penetration*

*RISE[®] cable penetrations are artificially
aged for a service life up to 50 years*



What will the performance of a fire safe multi-cable penetration be after years of service? **Remember that safety is at stake here.** This is the reason why the RISE[®] system has been artificially aged up to 50 years, after which the expanding properties of the rubber and the sealant were compared with new material. Only minor changes were noted! Temperature cycle on the RISE[®] system from -40 °C to ambient to +120 °C, and back, showed that the adhesion of FIWA[®] holds the system tight!

*RISE[®] multi-cable penetrations are exposed
to thermal cycling tests with positive results*

RISE[®] MULTI-CABLE TRANSITS: THE RAPID[®] SEALING SYSTEM

additional safety with RISE[®] multi-cable penetrations

* Naval Engineering Standard 711: Issue 2: Determination of the smoke index	passed
* Naval Engineering Standard 713: Issue 3: Determination of the toxicity index	passed
* ISO 4589 - 2 : 1996 Determination of the oxygen index	passed
* ISO 4589 - 3 : 1996 Determination of the temperature index	passed
* IMO Resolution A.653(16) Determination of low flame spread characteristics	passed
* Artificial ageing test Determination of properties after 25-50 years	passed
* Thermal cycling test Determination of adhesion at +120 °C / ambient / -40 °C (+212 °F / ambient / -40°F)	passed
* Naval Engineering Standard 510: Issue 2, Draft B: Shock (100 g _n) and vibration test (5-350 Hz) combined with 1 bar leak test afterwards	passed
* Naval Engineering Standard 814: Shock test, acceleration level 8378/s/s in two directions combined with 6.9 bar leak test afterwards	passed
* Naval Engineering Standard 510: Issue 2, Draft B: Leak test after a one hour fire test	passed
* General classification Helium gas leak test up to 1 bar	passed
* Nordtest method NT ELEC 030, modified for conducted attenuation	20-100 dB
* Sound damping test According to EN ISO 717-1:1996	70 dB
* Rapid rise fire test According to Mil-P-24705 of the US Navy	passed
* Dynamic cycling test Displacement 10 mm, 100,000 cycles, frequency 0.5 Hz	passed

To prove the outstanding quality and safety of the RISE[®] cable and pipe penetrations, the basic materials (FIWA sealant and FRR/LEHF rubber) have been subjected to additional tests. These tests have been carried out by official institutes: Warrington Fire Research and RAPRA Technologies in the United Kingdom, the Fire Technology Institute of the University of Ghent in Belgium and TNO Laboratories in The Netherlands. The RISE[®] cable and pipe penetrations have also been subjected to additional tests at official institutes such as DELTA Danish Electronics, Light and Acoustics Testing in Denmark, QinetiQ in England, South West Research Institute in USA and in-house under survey of the classification societies. To name some: sound tests, shock and vibration tests, rapid temperature rise tests, leak tests after a one hour fire test, EMC tests, A-0 test without insulation, dynamic cycling test, several configurations on watertightness and a helium gas leak test.



RISE® MULTI-CABLE TRANSITS: THE RAPID® SEALING SYSTEM



EC (MED) certificates according to EUROPEAN UNION COUNCIL DIRECTIVE 96/98 EC on MARINE EQUIPMENT have been issued by Det Norske Veritas certificates N° MED-B-4906 for RISE/ULTRA, N° MED-B-4908 for RISE/NOFIRNO multi-pipe and multi-all-mix penetrations and N° MED-B-4941 for SLIPSIL plugs and by Bureau Veritas certificates N° 09156/B2 EC for RISE, RISE/NOFIRNO and RIACNOF multi-cable penetrations and extended multi-cable penetrations, N° 11301/B0 EC for RISE-EMC multi-cable penetrations, N° 11302/A2 EC for RISE busbar penetrations and certificates N° 10035/B0 EC and N° 10710/B1 EC for RISE single and multi-pipe penetrations for metallic and plastic pipes.

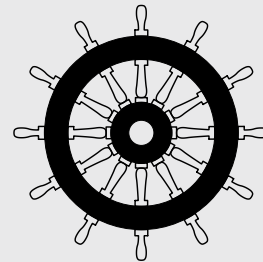

AMERICAN BUREAU of Shipping
BUREAU VERITAS
CHINA CLASSIFICATION SOCIETY
CHINA CORPORATION REGISTER of Shipping
DET NORSKE VERITAS
GERMANISCHER Lloyd
KOREAN REGISTER of Shipping
Lloyd's REGISTER of Shipping
Nippon Kaiji Kyokai
RUSSIAN MARITIME REGISTER of Shipping
TRANSPORT CANADA via DNV CERTIFICATES
USCG via MED CERTIFICATES

RISE

CERTIFIED BY
THE MAJOR
CLASSIFICATION
SOCIETIES

*Note: configurations may differ
per classification society.*



RISE[®] MULTI-CABLE TRANSITS: THE RAPID[®] SEALING SYSTEM

*only two different components for a
RISE[®] cable penetration: sleeves and sealant*

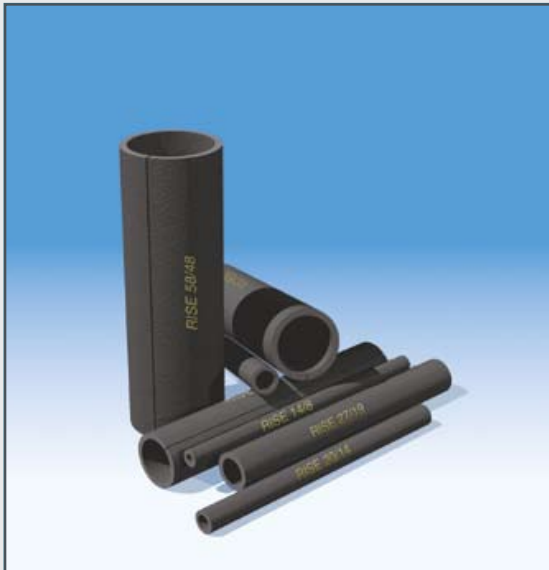

sleeve type	cable diameter	sleeve length (standard)	sleeve length (standard)	wall thickness
12/6	5 - 7	160	210	3
14/8	7 - 9	160	210	3
16/10	9 - 11	160	210	3
18/12*	11 - 13	160	210	3
20/14	13 - 15	160	210	3
22/16	15 - 17	160	210	3
27/19*	17 - 21	160	210	4
31/23	21 - 25	160	210	4
35/27	25 - 29	160	210	4
39/31	29 - 33	160	210	4
46/36	33 - 39	160	210	5
52/42	39 - 45	160	210	5
58/48	45 - 51	160	210	5
64/54	51 - 57	160	210	5
70/60	57 - 63	160	210	5

* filler sleeves are supplied non-split for ease of filling dimensions in mm

RISE[®] cable penetrations: non-toxic, halogen free components

For the RISE[®] insert and filler sleeves, a special rubber compound was developed known as FRR/LEHF (fire resistant rubber/low grade of expansion, halogen free). When this rubber is exposed to fire or temperatures in excess of 200 °C it expands five to ten times its original volume. During the expansion of the rubber a carbonized mass is formed, which has good properties of thermal insulation.

The FRR/EHF rubber is absolutely HALOGEN FREE (tested according to Naval Engineering Standard NES 713: Issue 3). Furthermore the FRR/LEHF rubber has a low smoke index (NES 711: Issue 2: 1981) and a very high oxygen index (ISO 4589-2: 1996).

The wall thickness of the sleeves is so chosen as to satisfy the requirements governing adequate separation of the cables.

Sometimes conduits are extremely oversized. For ease of filling of larger remaining spaces the filler sleeves 18/12 and 27/19 can be supplied as non-split multi-units of 10 pieces bonded together.

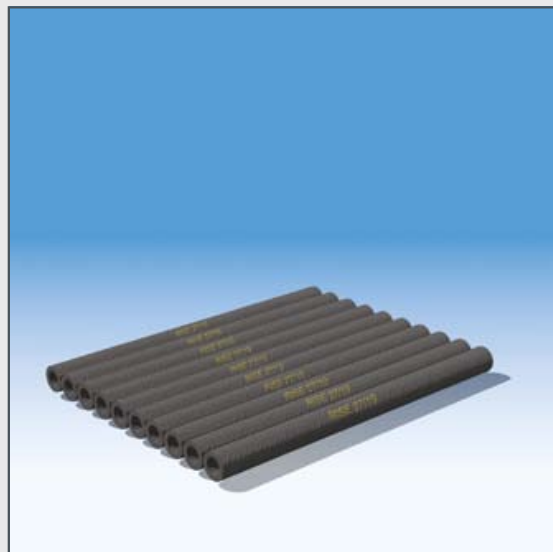

RISE® MULTI-CABLE TRANSITS: THE RAPID® SEALING SYSTEM

*only two different components for a
RISE® cable penetration: sleeves and sealant*

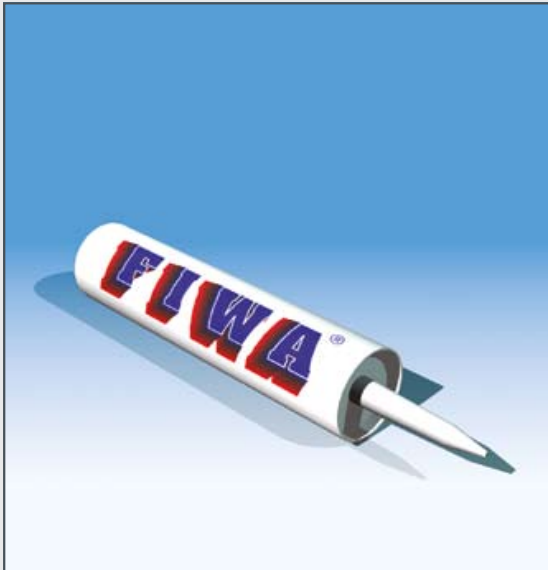

FIWA® is a fire-resistant sealant based on a single component silicone compound.

FIWA® is also water-repellent

High bonding strength

Weathering, UV and Ozone resistant

In the event of fire or at temperatures in excess of 200 °C the sealant expands to about five to ten times its original volume. During this process a porous mass is formed, which has excellent thermal insulation properties. In contrast to conventional materials that swell under severe heat exposure, the expansion of FIWA® sealant is not caused by intumescence, but by a chemical process (Intumescence means the occurrence of volume enlargement under the effect of heat, caused by the surface structure being inflated by fumes originating from the product). The advantage of this is that the expansion of FIWA® is not accompanied by formation of large amounts of fumes.

*optimum combination of viscosity, flow and
bonding capacity of FIWA® sealant*

PRODUCT INFORMATION

01) colour	dark grey
02) specific gravity	1.30 ± 0.03 g/cm ³
03) curing of top layer	0.5 - 1 hour depending on temperature and air humidity
04) service temperature	-50 °C up to +160 °C
05) tensile strength	1.15 MPa
06) elongation at break	125%
07) hardness	35 Shore A
08) elastic deformation	approx. 25%
09) resistance	UV, Ozone, arctic conditions
10) ageing	more than 20 years
11) supplied in	310 ml cartridges
12) storage	to be stored cool and dry min/max temperature = +5/+30° C
13) storage life	guaranteed 6 months; when applied later than 6 months after date of manufacturing, curing and adhesive properties have to be checked before application



FIWA is absolutely HALOGEN FREE (tested according to Naval Engineering Standard NES 713: Issue 3).

Furthermore FIWA has a low smoke index (NES 711: Issue 2: 1981) and a high oxygen index (ISO 4589-2: 1996),

and low flame spread characteristics according to IMO Resolution A.653(16).

RISE® MULTI-CABLE TRANSITS: THE RAPID® SEALING SYSTEM

1) The cables can be ducted through the conduit sleeve/frame in random order. It is most important that they are not pulled too tight in order not to hamper their separation when RISE® insert sleeves are inserted. Ask for our free installation video.

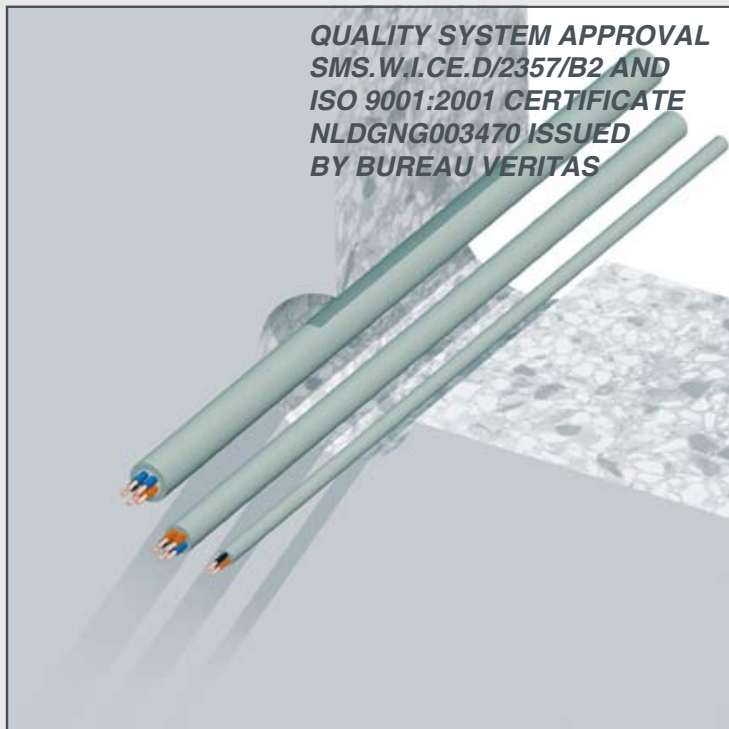

QUALITY SYSTEM APPROVAL
SMS.W.I.CE.D/2357/B2 AND
ISO 9001:2001 CERTIFICATE
NLDGNG003470 ISSUED
BY BUREAU VERITAS



2) After the cables have been ducted, RISE® insert sleeves are applied around each cable. The insert sleeves are split length-wise and can therefore be fitted around the cables in front of the conduit. See above.

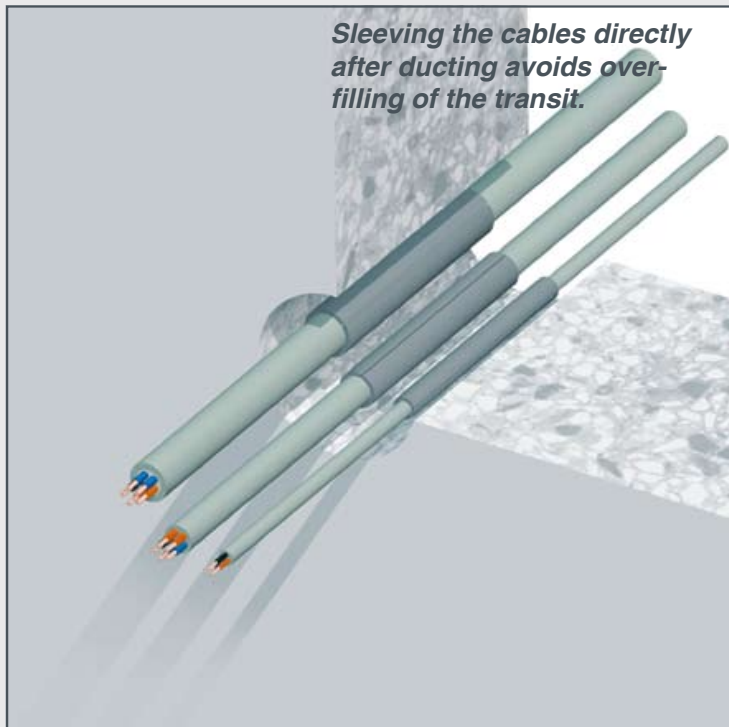

*Sleeving the cables directly
after ducting avoids over-
filling of the transit.*

RISE® MULTI-CABLE TRANSITS: THE RAPID® SEALING SYSTEM

3) The remaining free space in the conduit is filled with RISE® filler sleeves type 27/19 and 18/12.

For ease of filling the RISE® filler sleeves are delivered non-split. The ratio 27/19 to 18/12 should be about 2:1.

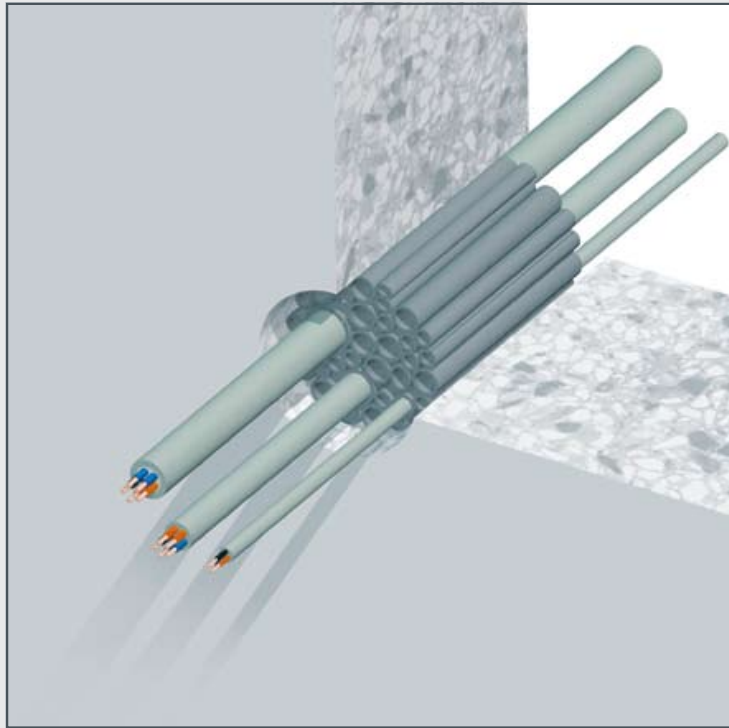

4) Push the insert/filler sleeves into the conduit in such a way as to leave about 20 mm free space at the front. The whole set of insert and filler sleeves should tightly fit into the conduit to offer sufficient mechanical stability.



Before applying the sealant it is advisable to check the status of the filling with insert and filler sleeves.



RISE[®] MULTI-CABLE TRANSITS: THE RAPID[®] SEALING SYSTEM

5) A 20 mm thick layer of FIWA[®] sealant is applied at each side of the conduit. Clean and dry the conduit opening and the cables thoroughly and remove any dirt, rust or oil residues before applying the sealant.



6) The conduit should be overfilled with FIWA[®] sealant, because some sealant will be pushed between and into the empty insert sleeves during further finishing. This will contribute to obtain higher tightness ratings.

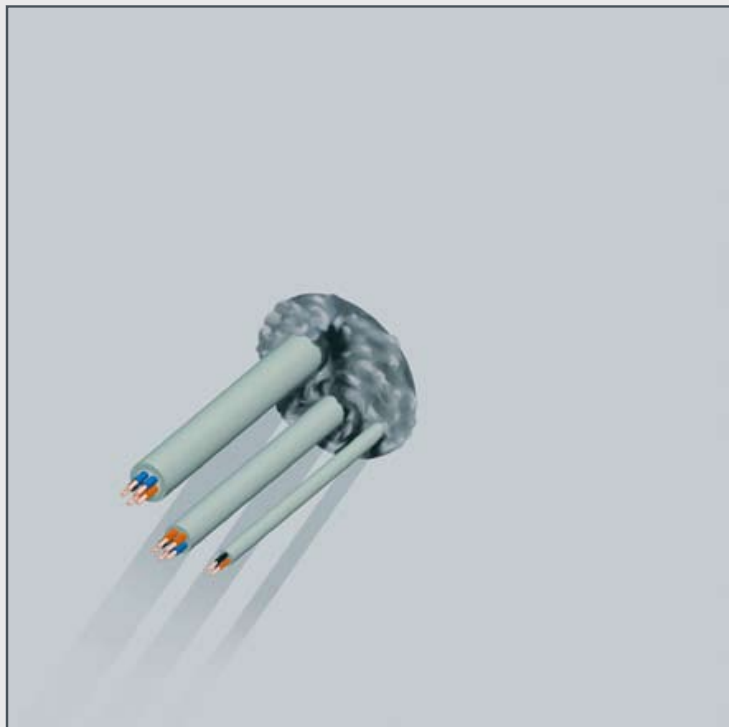

RISE[®] MULTI-CABLE TRANSITS: THE RAPID[®] SEALING SYSTEM

7) To smooth the surface of the FIWA[®] sealant layer, a cloth is sprayed with water. This prevents the sealant from sticking to the cloth.

Note: do not use soapwater!



8) The cloth is then used to press down the sealant layer. People with sensitive skin should use gloves when working with the FIWA[®]. Please refer to the Safety Data Sheet for more information.

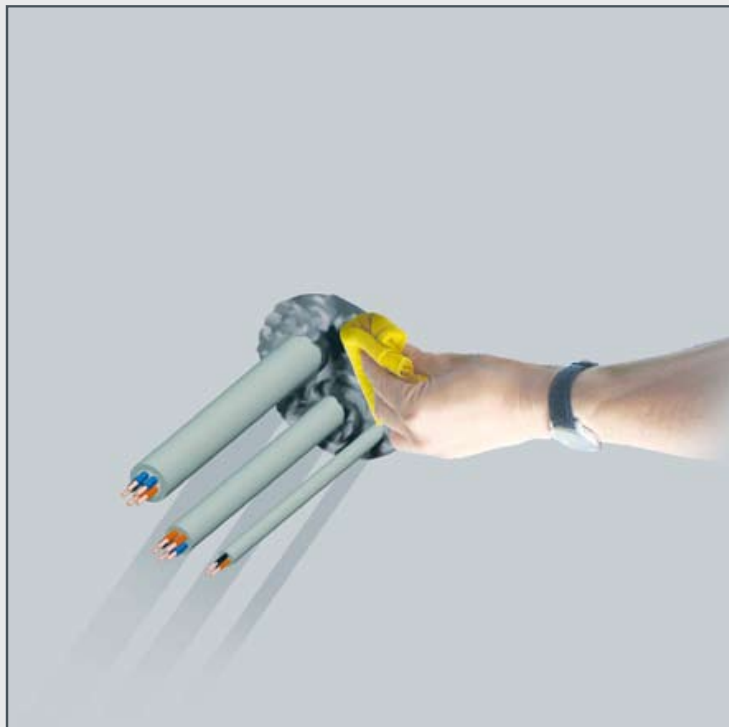

RISE® MULTI-CABLE TRANSITS: THE RAPID® SEALING SYSTEM

9) The FIWA® sealant between the cables is pressed down and smoothed by hand or with a spatula or putty knife.

This is essential to obtain an effective gas- and water tightness.

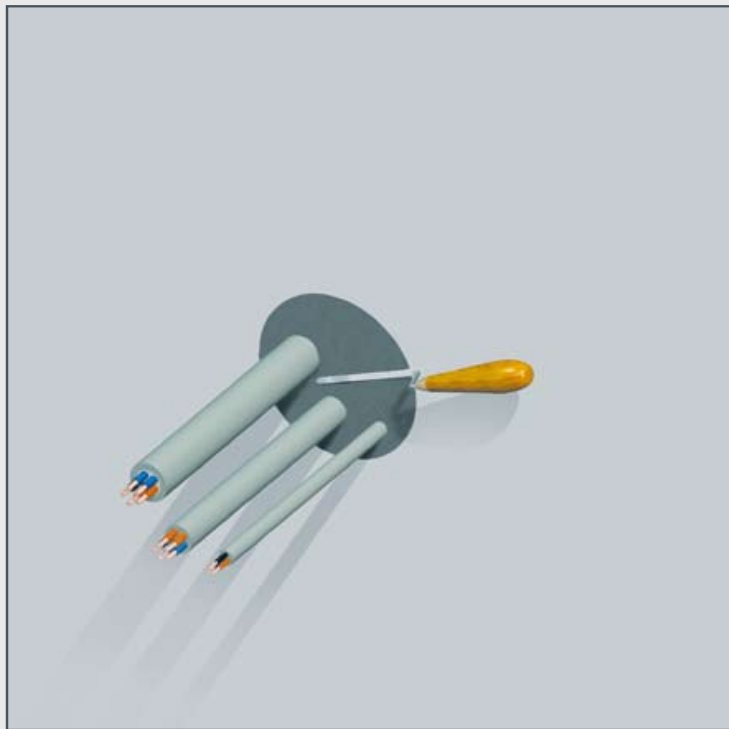

10) The surface can also be smoothed by hand. Just wet the hand thoroughly with soap and water.

No dirty hands when working with FIWA® and a very neat surface is the result. People with sensitive skin should use gloves when working with FIWA®.

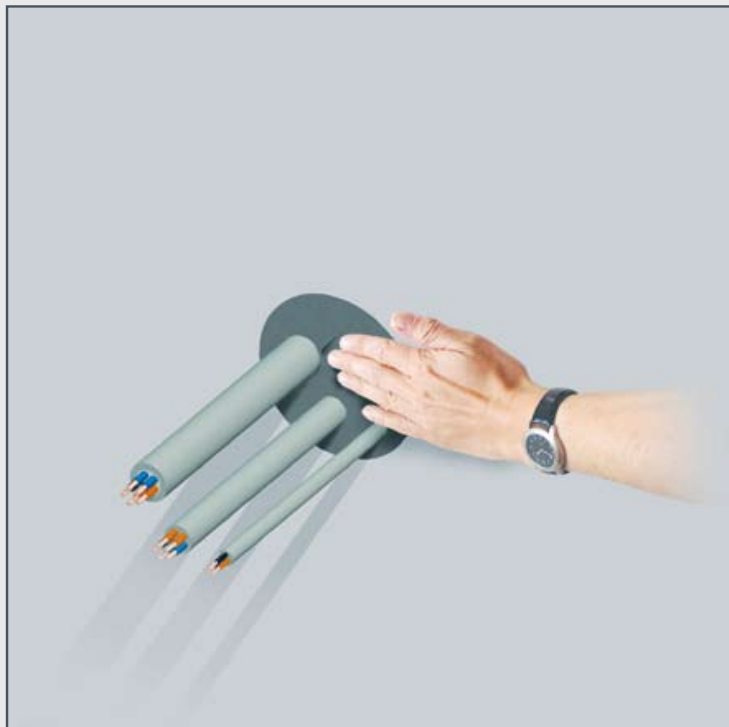

RISE® MULTI-CABLE TRANSITS: THE RAPID® SEALING SYSTEM

11) After smoothing is finished a last check should be taken if sufficient sealant is applied in between the cables especially at penetrations with larger amounts of cables. This is most important specially for water and gastight penetrations

to obtain optimum adhesion during the curing process of the sealant, the cables should be tightly fixed immediately after finishing the transit.

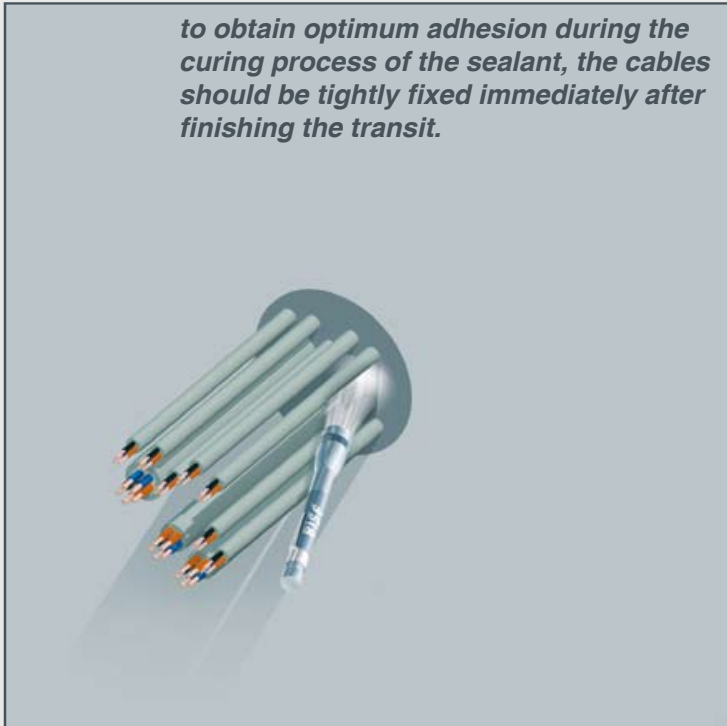

12) For fire rated penetrations the FIWA® sealant always has to be applied at both sides of the penetration. No extra insulation or coatings needed in front of the penetration with conduit depths of 200 mm.

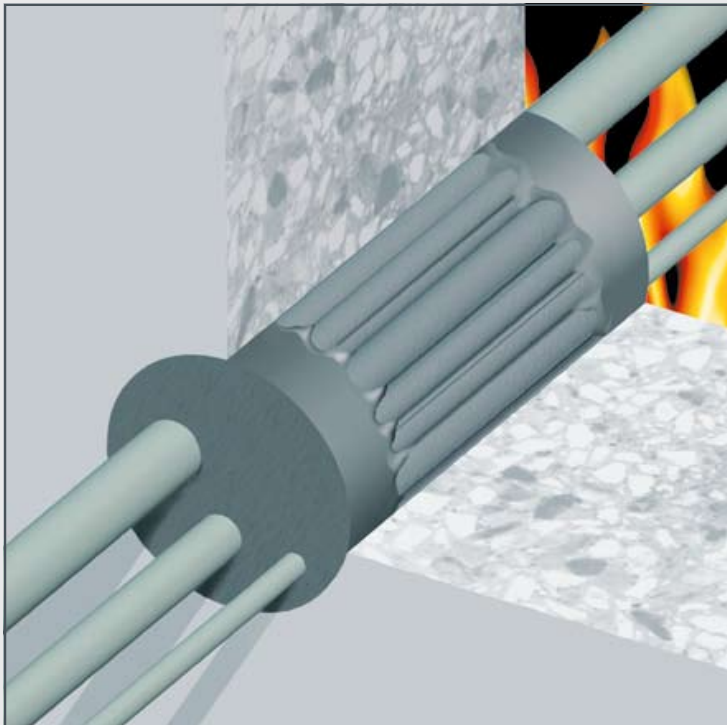

RISE[®] MULTI-CABLE TRANSITS: THE RAPID[®] SEALING SYSTEM

13) For vertical conduits it is advisable to select the insert sleeves a bit under-sized.

They will then cling to the ducted cables in such a way that they are prevented from sliding down.

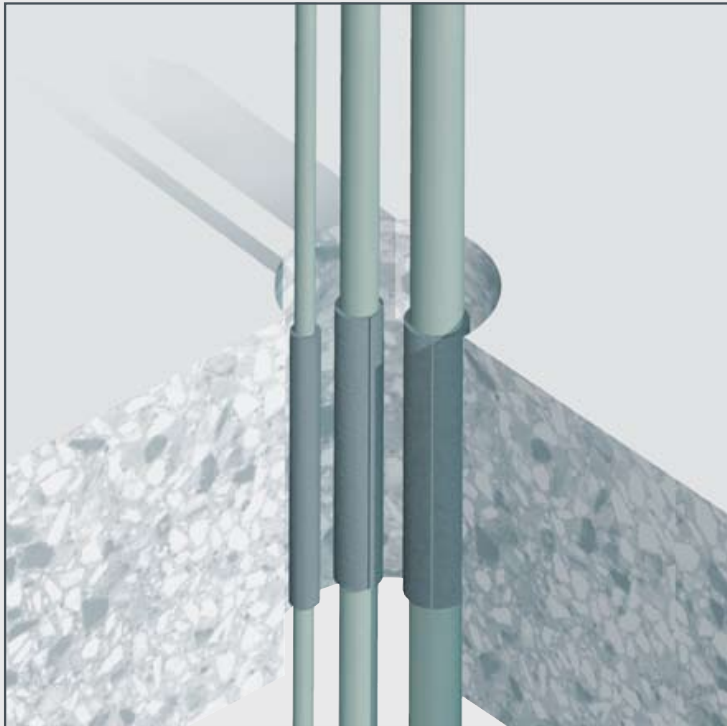

14) To prevent the filler sleeves from falling out of the conduit sleeve/ frame, they are bundled together to form a compact bundle. They are available in bundles of ten pieces. Contrary to the insert sleeves, filler sleeves are delivered in a non-split version.

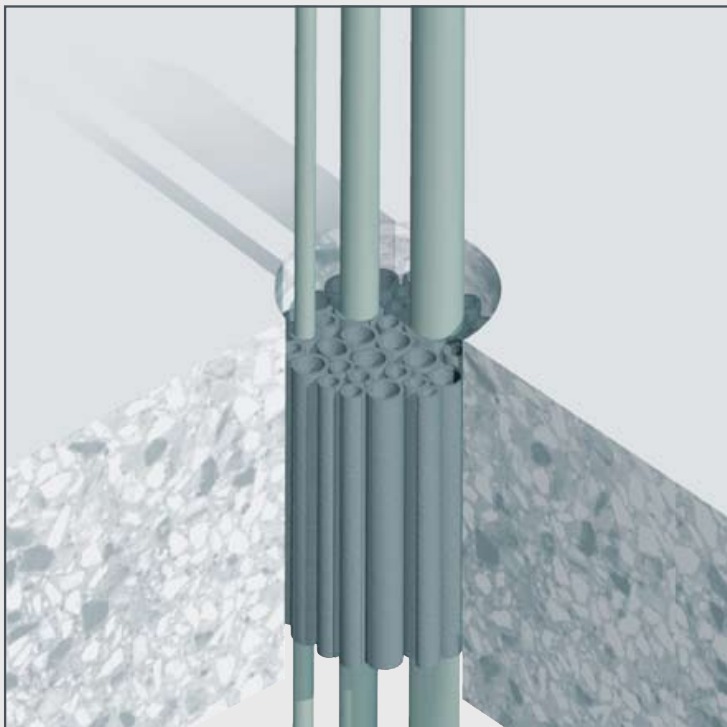

RISE[®] MULTI-CABLE TRANSITS: THE RAPID[®] SEALING SYSTEM

2a) Pull a set of bundled cables through the conduit and place a RISE[®] insert sleeve around the cable.
See the specifications on pages 26 and 27.

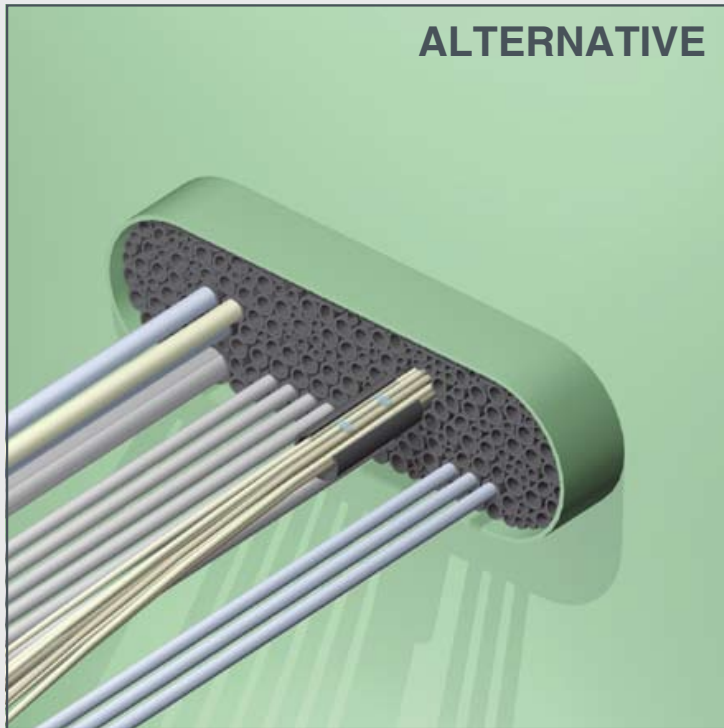

4a) Push the insert sleeve into the conduit in such a way as to leave about 20 mm free space at the front,

The conduit to be finished as described on pages 17-20.

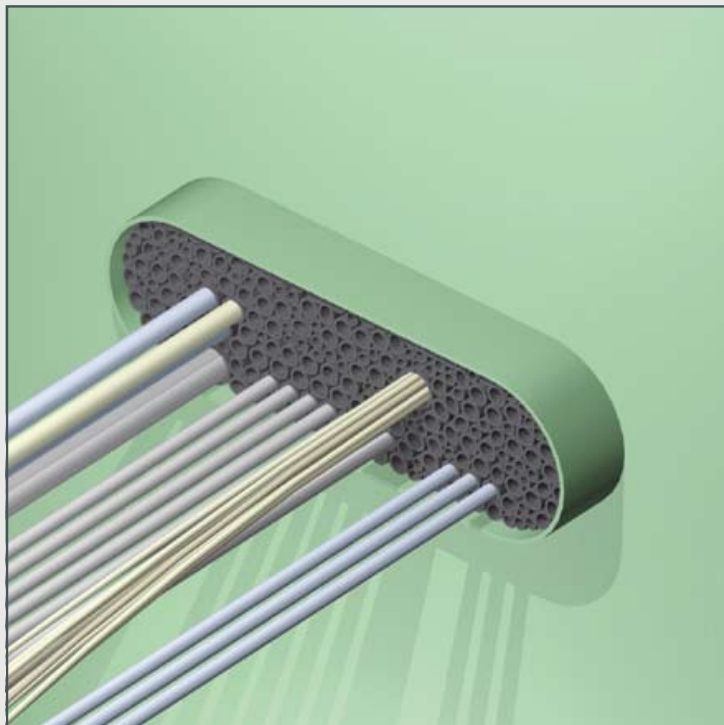

RISE® MULTI-CABLE TRANSITS: THE RAPID® SEALING SYSTEM

The RISE® sealing system allows cables to be ducted through conduit openings in a bent, curved or oblique way without any adverse impact on sealing performance. Due to the fact that RISE® is an adhesive system, only proper contact surfaces are needed to obtain tightness. Sufficient cable separation is a must to enable the FIWA® sealant to be applied in between the cable set.

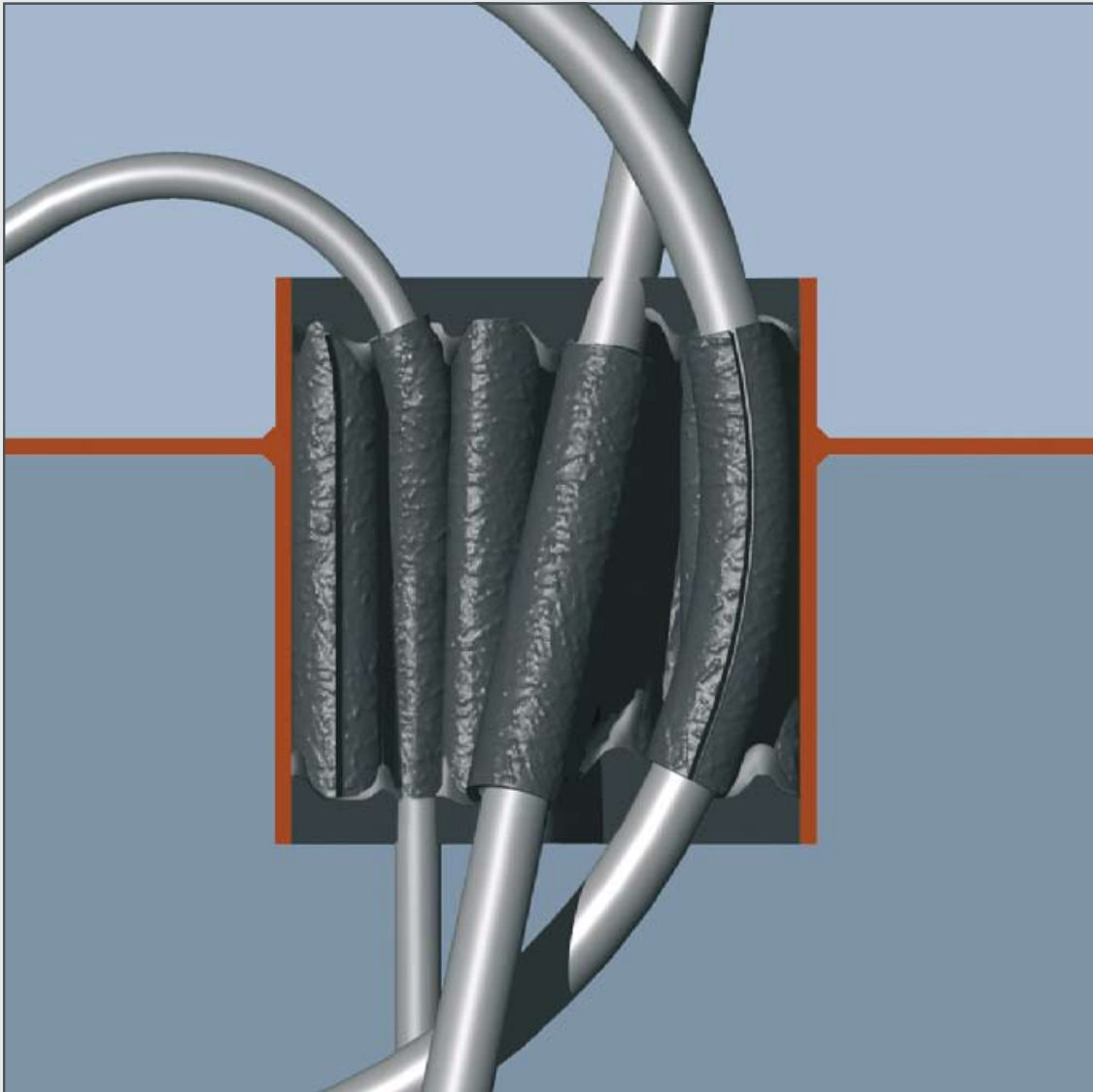

RISE® multi-cable penetrations are an alternative for the casting compounds and block systems in water-tight walls and floors. Very easy to install. No skilled labour required. The very limited amount of different parts makes this system easy to handle on site. Use is made of rubber inserts (placed around the cables) and filler sleeves. The insert sleeves act as a spacer to separate the cables and the filler sleeves are used to create a carrier for the sealant. They are split lengthwise to enable ease of installation. The sleeves should not be applied in lengths shorter than 60 mm and should fit snugly in the conduit opening. A layer of FIWA® sealant about 20 mm thick is applied on the resultant carrier.

RISE[®] MULTI-CABLE TRANSITS: THE RAPID[®] SEALING SYSTEM

DIAGRAMMATIC OVERVIEW

- NO EXTRA INSULATION REQUIRED AT THE FRONT OF THE PENETRATION OR IN BETWEEN THE CABLES AND ALSO NO COATING NEEDED ON THE CABLES

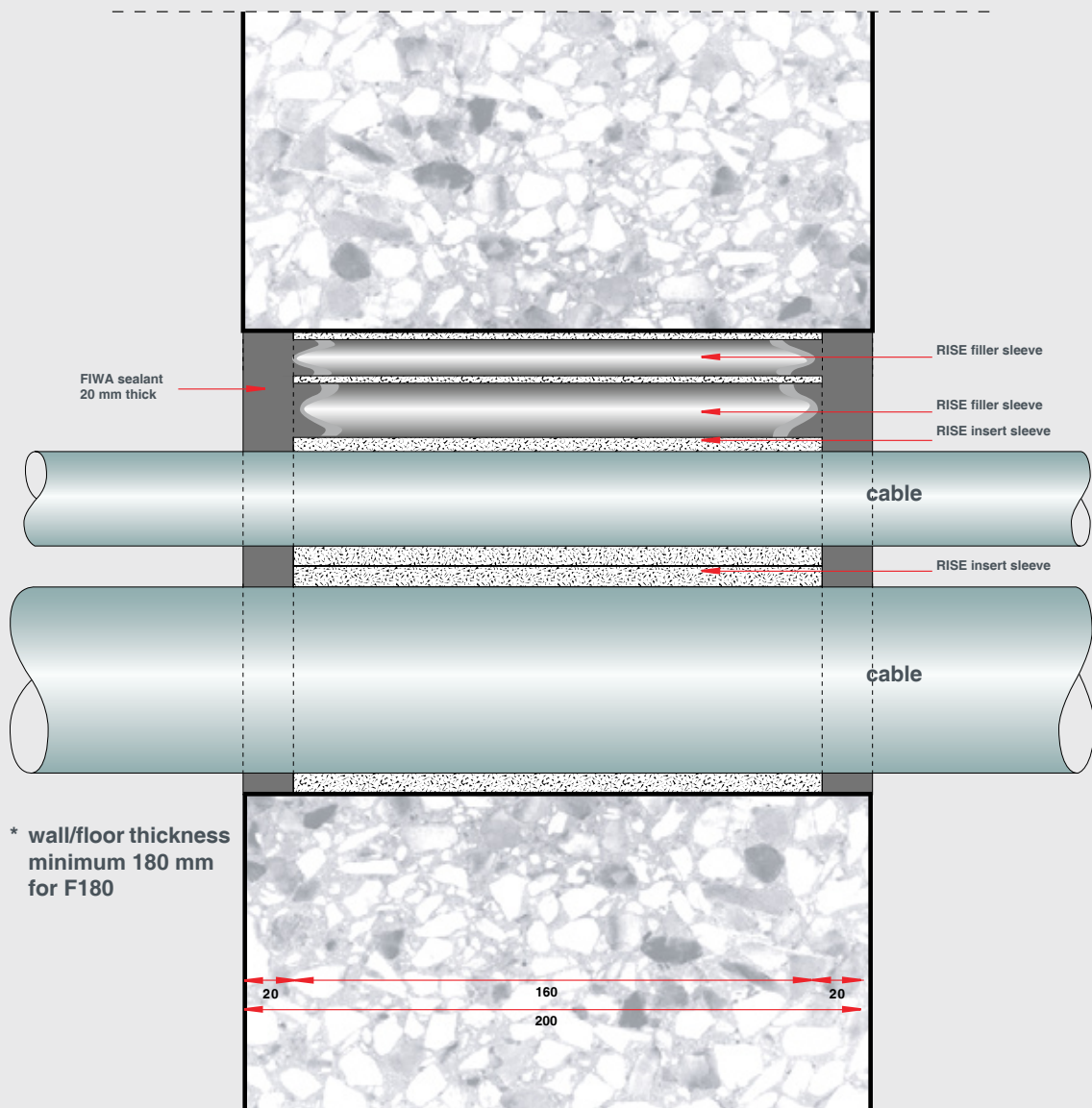

* wall/floor thickness
minimum 180 mm
for F180

** standard length of the
RISE insert and filler
sleeves 160 and 210
mm. Other lengths
are available on request.



RISE® MULTI-CABLE TRANSITS: THE RAPID® SEALING SYSTEM

The most simple way to obtain a watertight RISE® penetration is to place insert sleeves with a length of 60 mm around the cables and to fill the remaining space in the conduit with 60 mm long filler sleeves. Then apply a layer of 20 mm FIWA® sealant at both sides of the penetration. Conduit length 100 mm. Tightness 2.5 bar. LRS certificate APE 0109113/1.

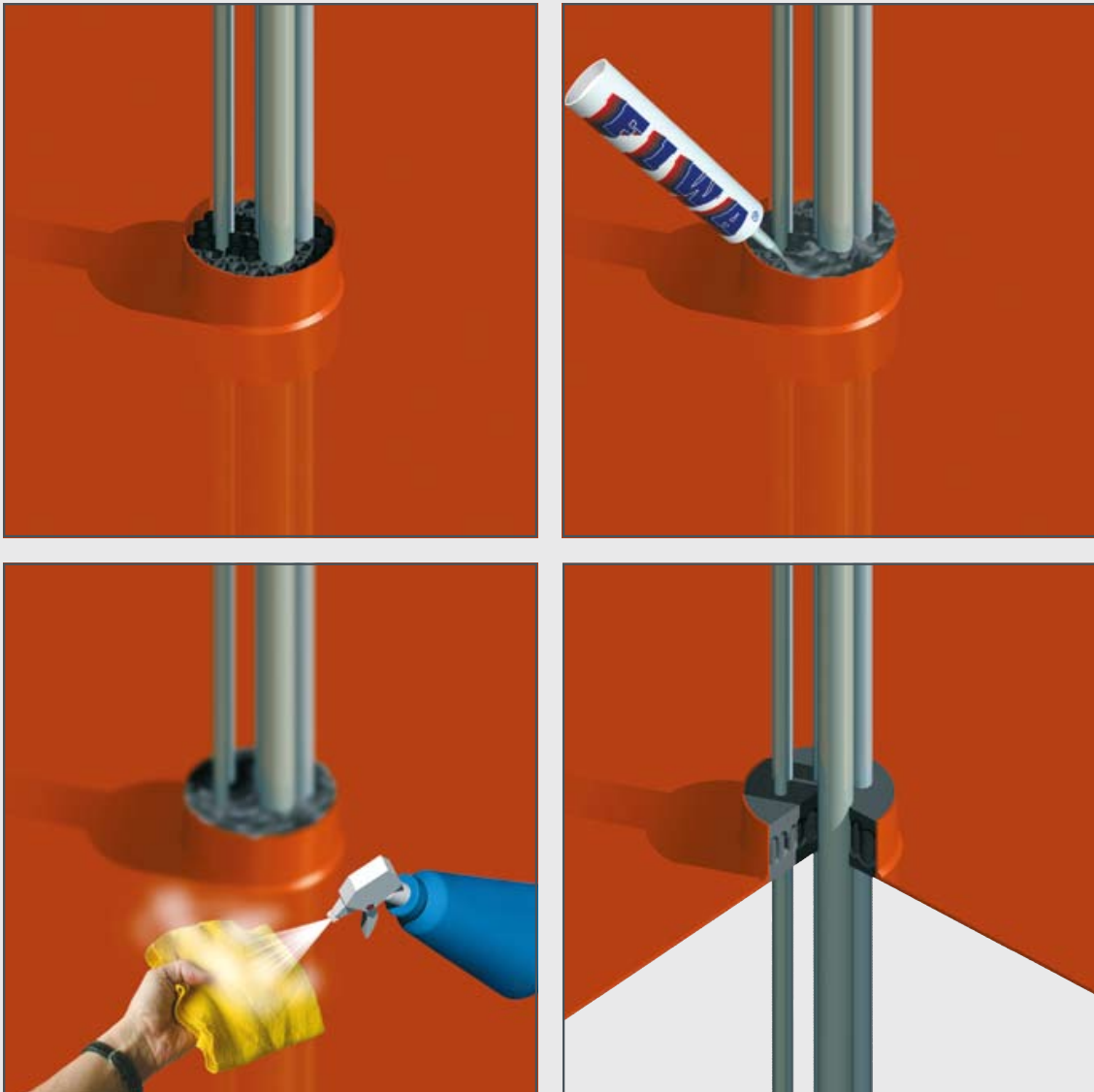

RISE® multi-cable transits are also used for water or gas tight conduits in buildings and constructions. When fire rating is not a requirement, the conduit length for only water and gas tight conduits can be reduced substantially. With a view on ease of installation, it is advisable not to use insert and filler sleeves with a length shorter than 60 mm. We always recommend to apply a layer of FIWA® sealant about 20 mm thick on both sides of the penetration. The above configuration with an overall length of 100 mm is approved for so-called B-15 penetrations which offer a fire integrity of 30 minutes minimum and a thermal insulation of 15 minutes. This means a fair degree of fire rating coupled with gas and water tightness.

RISE® MULTI-CABLE TRANSITS: THE RAPID® SEALING SYSTEM

The RISE® systems and/or components can be used in a wide variety of applications and can easily be combined with other product lines of BEELE Engineering. This means that fire safe and gas and watertight ducting in the field allows for numerous solutions. The configurations showed below are all fire tested and offer with ease F-60 ratings.

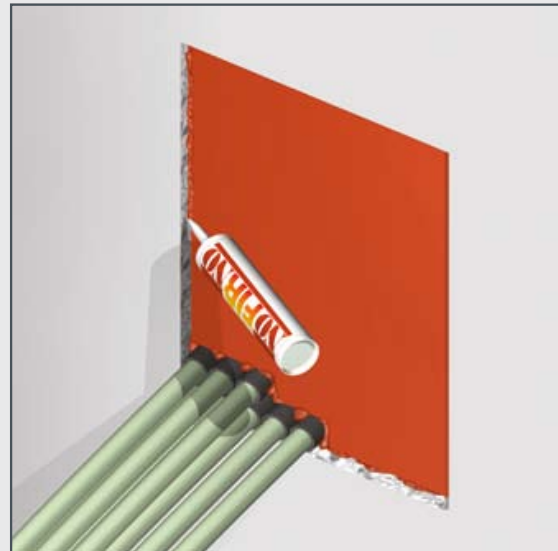
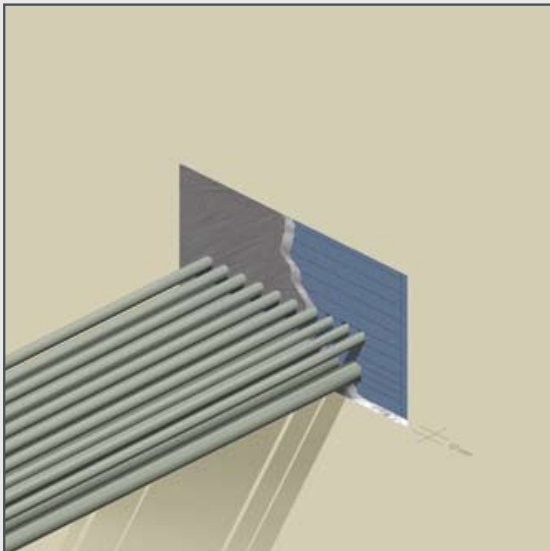
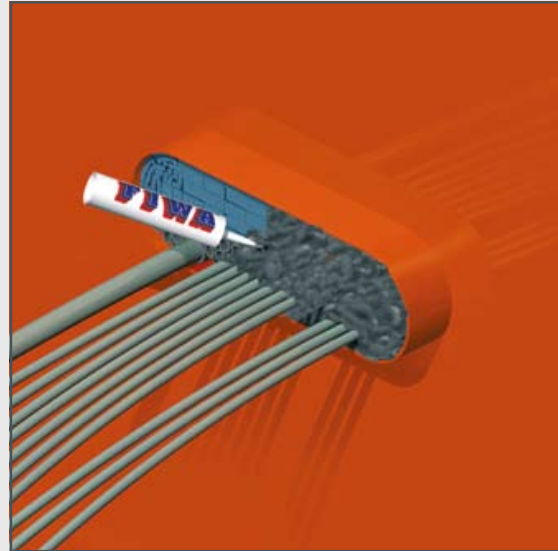

At the top left a configuration is shown to use the RISE® system for the fire safe ducting of bus bars through walls and floors.

At the top right a combination of RISE® and ACTIFOAM® is shown. This configuration is used to fill larger open spaces in RISE® cable penetrations.

At the bottom left an ACTIFOAM® penetration is sealed with a layer of FIWA® to obtain not only a fire rated but also a water tight penetration.

At the bottom right a NOFIRNO® cable penetration is shown whereby the cable separation is carried out with RISE® sleeves.

RISE[®] MULTI-CABLE TRANSITS: THE RAPID[®] SEALING SYSTEM

Existing installations can easily be upgraded to the RISE[®] sealing system using extension frames. Generally the depth of the transit frames is too short to offer the required thermal insulation during a fire.

To fulfil this criterion for all types of cables a minimum depth of 200 mm is an absolute must. Otherwise the transit and the front side of the penetration have to be totally insulated. By making use of extension frames the required depth can easily be obtained.

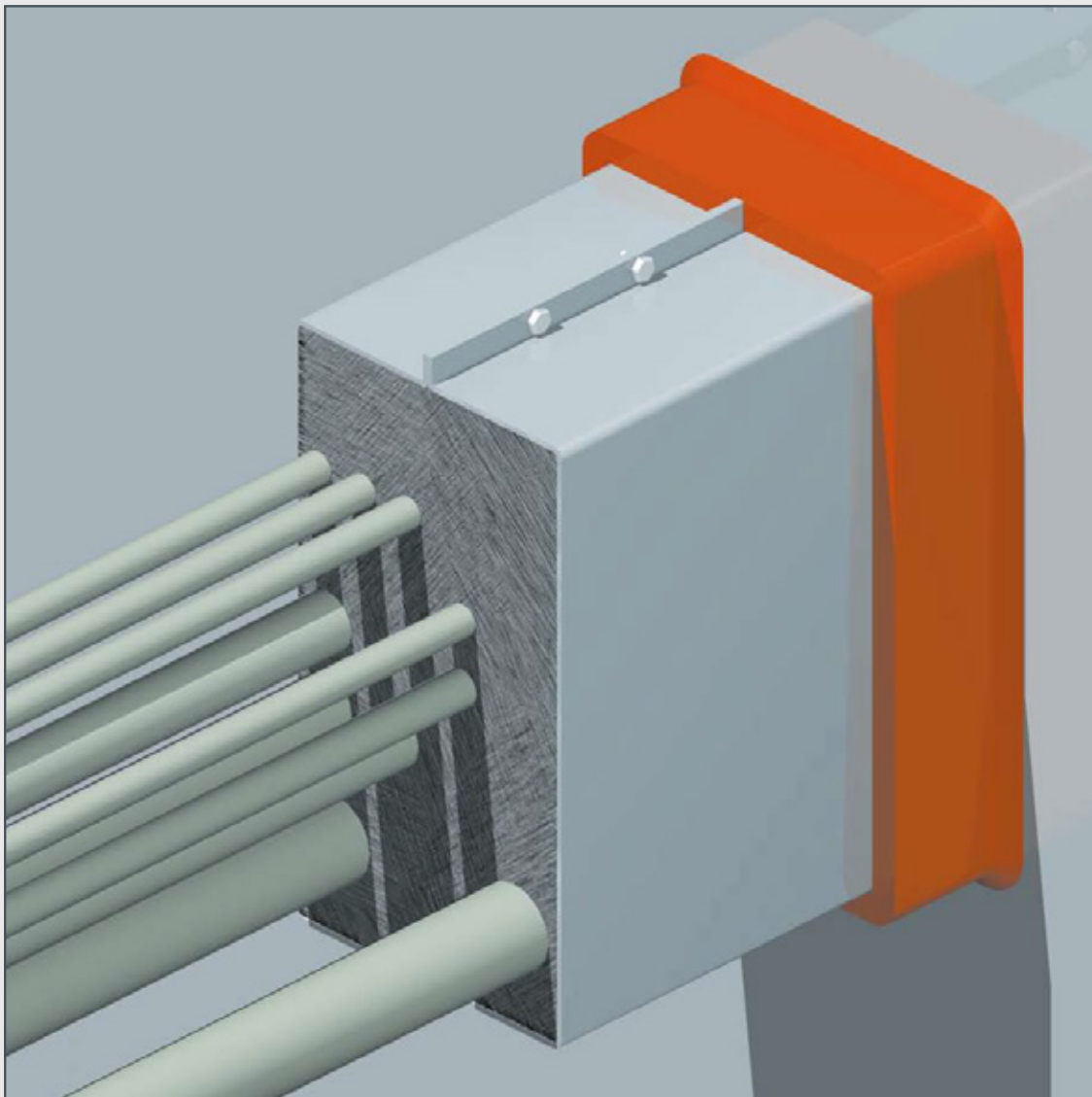

The advantage of upgrading with RISE[®] is not only an improvement of the fire rating, but it also gives the option to acquire more available space for ducting extra cables. The extended RISE[®] penetration filled with the same configuration of cables as tested with the normal RISE[®] penetrations and with the same sizes, has been successfully tested according to IMO Resolution A.754(18) for use in both A0 - A60 class bulkheads and decks. CE (MED) certificate N° 09156/B0 EC.

RISE® MULTI-CABLE TRANSITS: THE RAPID® SEALING SYSTEM

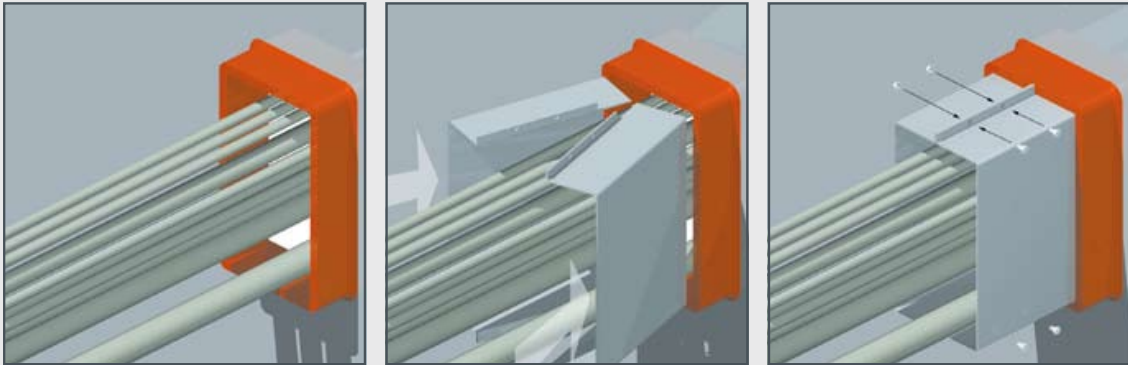

Remove all block components from the transit frame, if any. Remove any dirt or grease from the inside of the frame. Position the two halves of the EXTEND-A-FRAME around the bundle of cables, then push the EXTEND-A-FRAME into the transit frame. The fitting must be very tight for stability reasons. The flanges on the top and bottom of the EXTEND-A-FRAME must be firmly seated against the transit frame. Install the bolts and nuts on the top and bottom flanges. Tighten the bolts on top and bottom flanges.

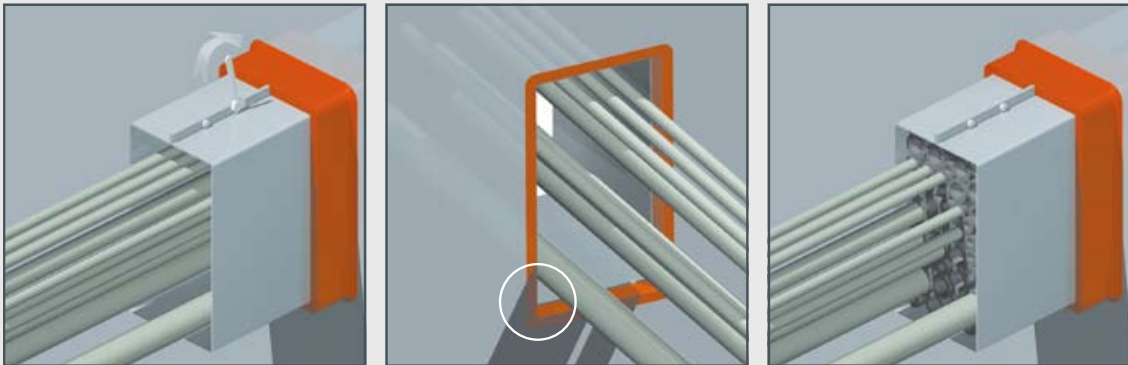

The flanges are 10 mm high, corresponding with the wall thickness of the block system transits. This enables the EXTEND-A-FRAMES to fit in multi-transit units without any problems. The EXTEND-A-FRAME, positioned in the transit frame, leaves 20 mm free at the back of the transit frame for the bonding of the FIWA® sealant to that transit frame. This is necessary to obtain a tight seal. Place a RISE® insert sleeve around each cable. Any empty space is filled with RISE® filler sleeves.

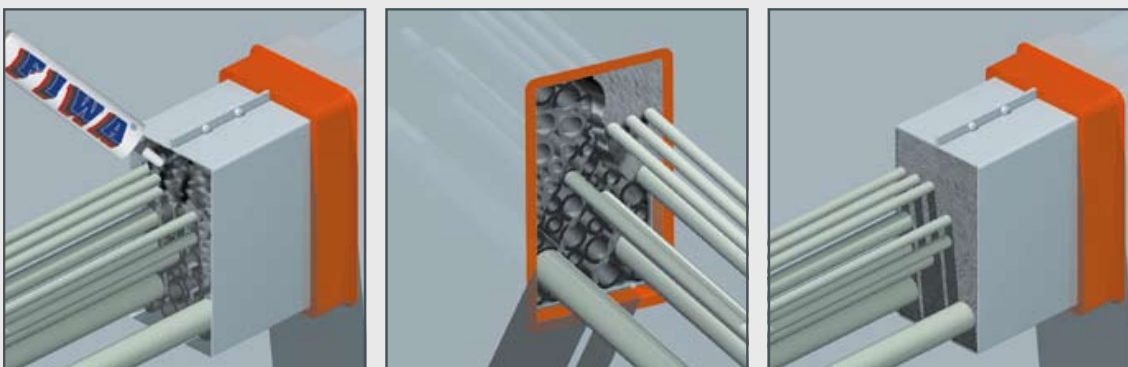

Center the RISE® sleeves within the conduit so as to leave 20 mm free space at the front and the back of the transit. A 20 mm layer of FIWA® sealant is applied at both sides of the transit. Refer to the step by step installation instructions for RISE® multi-cable penetrations for final finishing of the transit.

For optimum stability, the EXTEND-A-FRAME should be spot welded or bolted to the existing frame. For larger frame configurations an option is to install a frame around the existing transit frame spot welded to the deck or bulkhead.

RISE® instantly doubles the usable space inside any block system transit frame

RISE® MULTI-CABLE TRANSITS: THE RAPID® SEALING SYSTEM

Adding extra cables is an easy job. Cut away the sealant layer at both sides of the penetration with a knife or a hollow punch in a tapering shape as shown above.

This creates a good foundation for the sealant mass to be applied later.

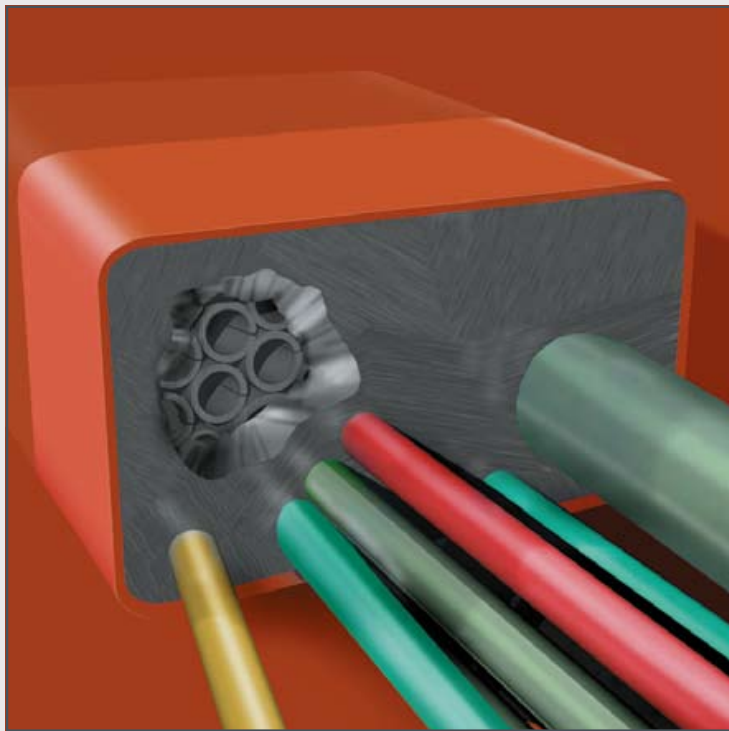

Pull the cable through one of the empty filler sleeves with an inner diameter more or less corresponding to the outer diameter of the cable.

Refill the opening in the sealant layer at both sides of the penetration with sufficient FIWA® sealant.

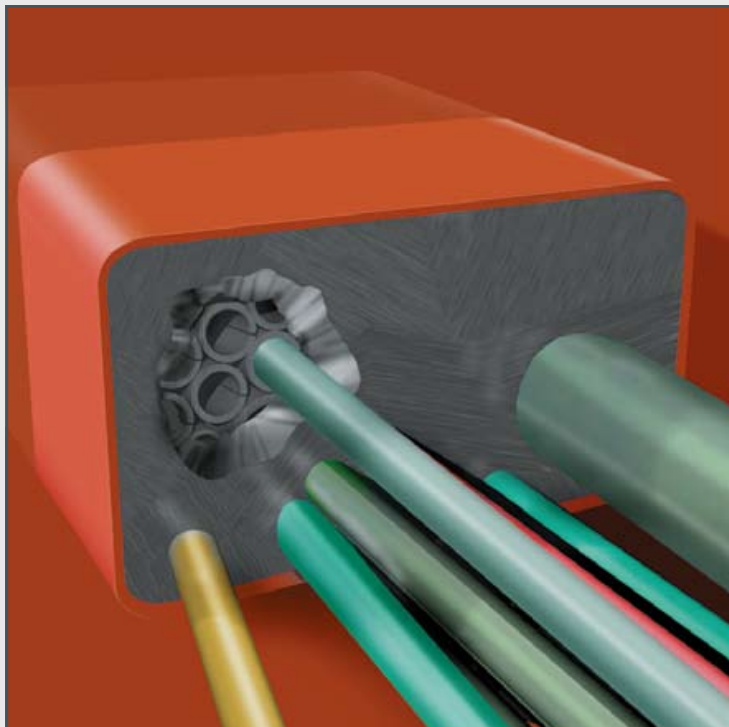

RISE® MULTI-CABLE TRANSITS: THE RAPID® SEALING SYSTEM

If the empty filler sleeves are not fitting to the size of the cable to be ducted, a number of these insert sleeves must be removed from the penetration. Install a fitting insert sleeve (with some filler sleeves if necessary) in the open space in the penetration.

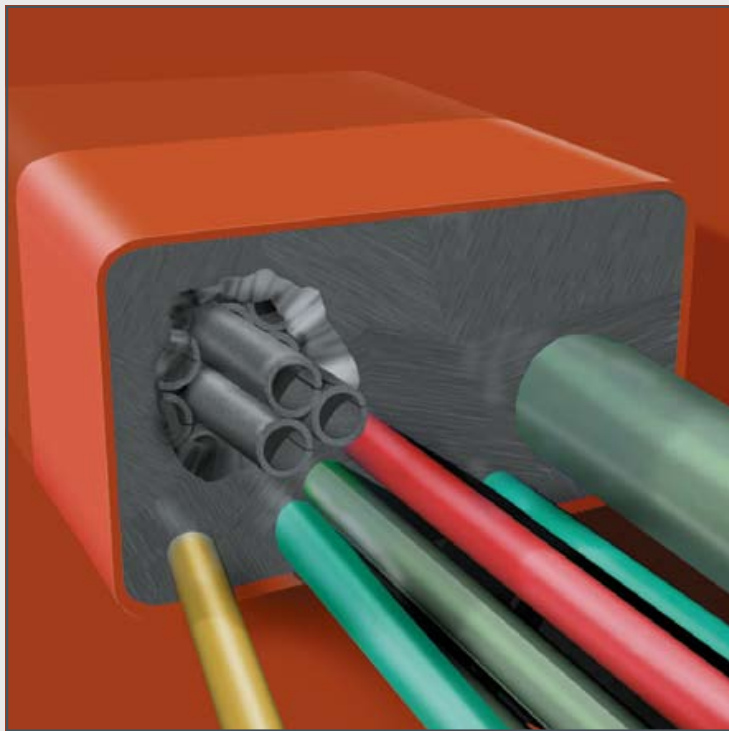

Pull the cable through the fitting insert sleeve that has now been installed. Refill the openings cut in the sealant layer at both sides of the penetration with sufficient FIWA® sealant. The FIWA® sealant is pressed down firmly and smoothed with a dampened cloth.

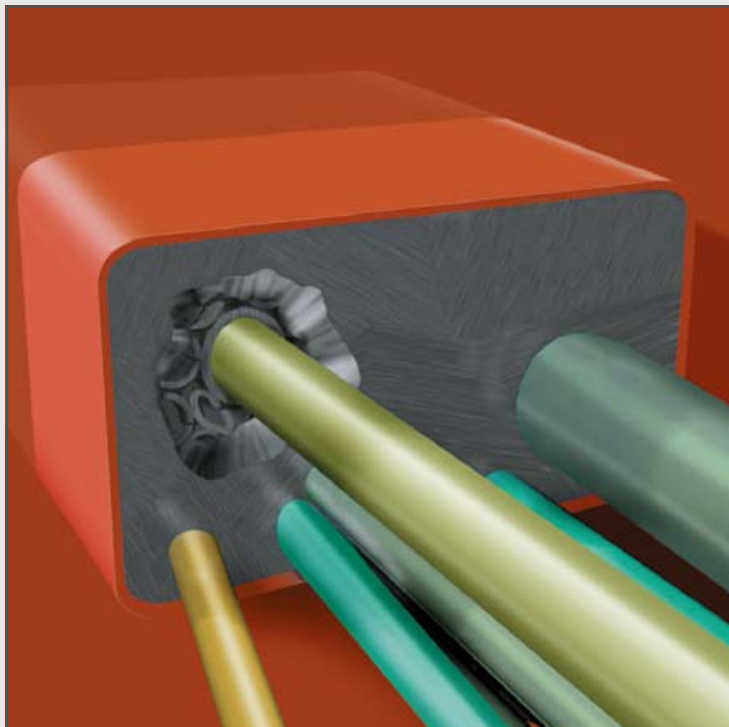

RISE® MULTI-CABLE TRANSITS: THE RAPID® SEALING SYSTEM

For the EMC protection of cable penetrations entering shielded areas, an electrically conductive sealant/flexible rubber is developed for the RISE® multi-cable penetrations type EMC. Tests carried out in our laboratories have shown that the electrical resistance from braiding to mass is about 1-2 ohm.

Attenuation tests at DELTA Electronics Testing/Denmark have proven the outstanding damping properties of the RISE® EMC sealing system.

CONDUCTON®

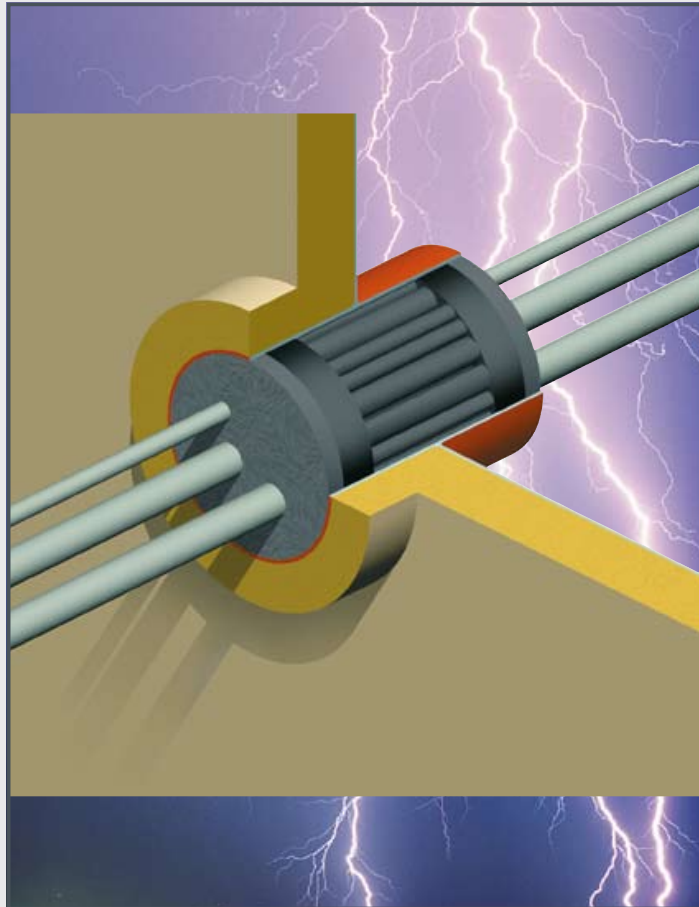

CONDUCTON®

In case the penetrations have to be only EMC proof, the length of the conduit can be reduced substantially. Only 40 mm CONDUCTON® putty/flexible rubber for the conductive filling of the cavity in between the layers of FIWA® sealant can be used. The CONDUCTON® flexible rubber is most easy to apply. The attenuation with the flexible rubber is the optimum; the attenuation of the CONDUCTON® putty is less.

UV and ozone resistant. Gas and water tight. Fire safe. CE certificate 11301/A2 EC.

Attenuation tests at DELTA Electronics Testing/Denmark have proved the good attenuation values achieved by the RISE®-EMC system based on a single layer of CONDUCTON® flexible rubber.
Damping: **35-85 dB.**

The RISE®-EMC system based on 2 layers of 40 mm CONDUCTON® flexible rubber.
Damping: **52->100 dB.**
A RISE®-EMC penetration based on the conductive putty shows a lower value.
Damping: **10-30 dB.**

RISE® MULTI-CABLE TRANSITS: THE RAPID® SEALING SYSTEM

*two different solutions for a RISE®-EMC
cable penetration: rubber or putty*



CONDUCTON® flexible rubber is used to fill the cavity around the ducted cables in the conduit sleeve in stead of making use of the putty. This rubber can be modelled by hand and offers the highest attenuation.

CONDUCTON® flexible rubber is absolutely HALOGEN FREE and has a toxicity index of 0,00 (tested according to Naval Engineering Standard NES 713: Issue 3).

Furthermore CONDUCTON® has a low smoke index (NES 711: Issue 2: 1981), an oxygen index of 38,2% (ISO 4589-2: 1996), and a temperature index of 294 °C (ISO 4589-3: 1996).

CONDUCTON® flexible rubber fullfils the criteria for use on board of UK Navy vessels.

*very high attenuation values with RISE®-EMC
cable penetrations feasible*

PRODUCT INFORMATION

01) colour	black
02) specific gravity	1.30 ± 0.03 g/cm ³
03) curing of top layer	0.5 - 1 hour depending on temperature and air humidity
04) service temperature	-50 °C up to +160 °C
05) tensile strength	0.80 MPa
06) elongation at break	40%
07) hardness	35 Shore A
08) elastic deformation	approx. 25%
09) resistance	< 100 Ω
10) ageing	more than 20 years
11) supplied in	310 ml cartridges
12) storage	to be stored cool and dry min/max temperature = +5/+30° C
13) storage life	guaranteed 6 months; when applied later than 6 months after date of manufacturing, curing and adhesive properties have to be checked before application



CONDUCTON® putty is an electrically conductive sealing putty based on a single component silicone compound.

The level of attenuation obtained with any of the RISE®-EMC transits is partly dependent on:

- a) *the distance between the ducted pipe and the penetration wall*
- b) *the contact surface with the conductive materials*
- c) *the compact filling of the conductive mass*
- d) *the condition of the contact surface in the conduit pipe*

RISE® MULTI-CABLE TRANSITS: THE RAPID® SEALING SYSTEM



1) At the place where the CONDUCTON® flexible compound is to be applied, the penetration should be bare steel without primer and thoroughly cleaned to ensure effective connection to earth.

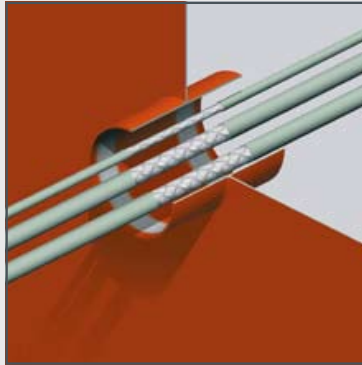

2) Remove the cable sheathing over a length that is 40 mm shorter than the length of the penetration, in such a way that the front face of the exposed braiding is situated about 20 mm inside the conduit at both sides.

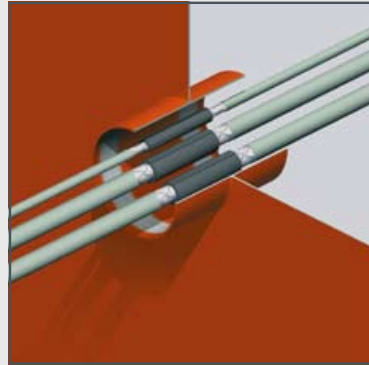

3) RISE® sleeves 120 mm shorter in length than the penetration are then fitted around the ducted cables and pushed into the penetration. The exposed braiding should extend 40 mm outside the sleeves.

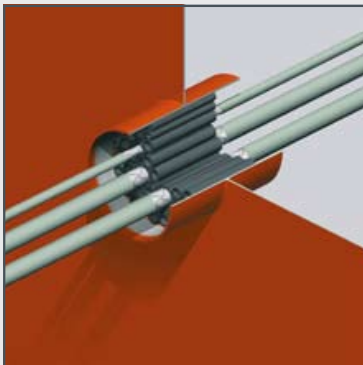

4) The remaining space inside the penetration is then packed with RISE® filler sleeves. Push the filler sleeves into the penetration in the same way as the sleeves fitted around the cables. Make sure that the sleeves fit tightly.

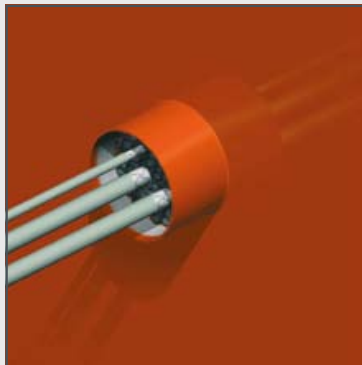

5) Push the insert/filler sleeves into the penetration in such a way as to leave about 60 mm free space at both sides. Take care that the exposed braiding extends 40 mm outside the sleeves at each side.

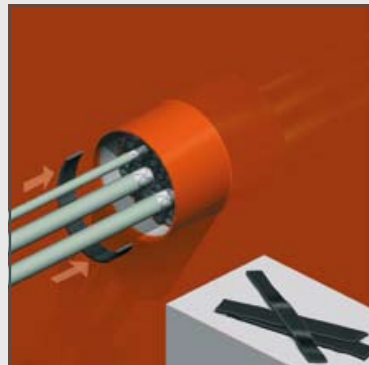

6) Then apply layers of CONDUCTON® flexible rubber strips 40 mm wide against the inside wall of the penetration.

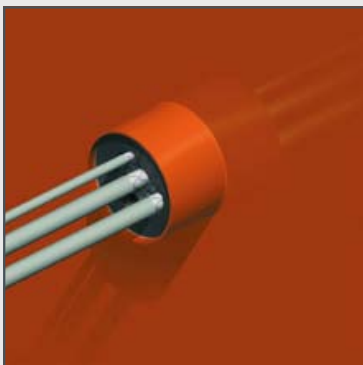

7) Pack the free space inside the penetration with lengths of strip. Compress the filling from time to time firmly to obtain a solid mass of flexible rubber and a good contact with the coaming/sleeve.



8) Pack the remaining small spaces around the cables with spare pieces of flexible rubber strip. Then press them down firmly with a piece of wood in order to obtain a good contact with the braiding.



9) Firmly press down the mass once more by hand. This is extremely important to ensure effective conductivity. Then apply the CONDUCTON® flexible rubber at the other side of the penetration in a similar way.

RISE[®] MULTI-CABLE TRANSITS: THE RAPID[®] SEALING SYSTEM

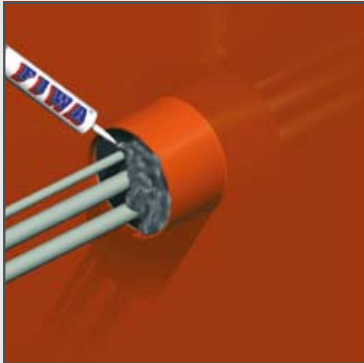

10) At both sides of the penetration about 20 mm free space should be present to enable the application of the FIWA[®] fire safe, water tight sealing compound. First clean the inside wall of the penetration very thoroughly.



11) To smooth the surface of the FIWA[®] sealant layer, a cloth is sprayed with water. This prevents the sealant from sticking to the cloth.
Note: do not use soap water!



12) The cloth is then used to press down the sealant layer. People with sensitive skin should use gloves when working with the FIWA[®]. Please refer to the Safety Data Sheet for more information.



13) The surface can also be smoothed by hand. Just wet the hand thoroughly with soap and water. People with sensitive skin should use gloves when working with the FIWA[®].

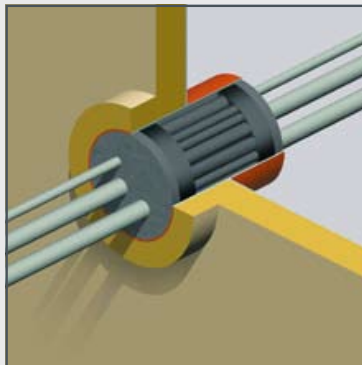

14) For A-class penetrations the conduit sleeve/frame needs to be insulated only at the insulated side of the bulkhead or at the lower side of the deck.
No extra insulation needed in front of the penetration.

CONDUCTON

The level of attenuation obtained is partly dependent on:

- the distance between the ducted cable and the penetration wall
- the contact surface with the conductive materials
- the compact filling of the conductive mass
- the condition of the contact surface in the conduit pipe

If the damping values are not required to comply with extremely high requirements, a 40 mm thick layer of CONDUCTON[®] flexible rubber at one side of the penetration will be sufficient. The penetration can be 40 mm shorter.

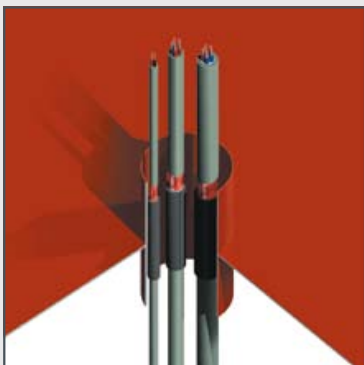

FOR RISE[®]-EMC MULTI-CABLE PENETRATIONS USE CAN ALSO BE MADE OF THE CONDUCTON[®] SEALING PUTTY. THE ATTENUATION IS LESS THAN WITH THE CONDUCTON[®] FLEXIBLE RUBBER.

RISE[®] MULTI-CABLE TRANSITS: THE RAPID[®] SEALING SYSTEM



CONDUCTON[®] is an electrically conductive putty based on a single component silicone compound. CONDUCTON[®] is also water-repellent. The putty adheres well to metal substrates and is reasonably elastic. CONDUCTON[®] contains components with a unique morphology to obtain the necessary high grade of conductivity. CONDUCTON[®] has a measured resistance of 50-60 Ohm. Optimum contact with the cable or structure to be shielded is essential for effective EMC protection. Measurements have shown that the attenuation is in the range of 10 - 30 dB, when applied with a surface contact of 40 mm for pipe and cable penetrations. CONDUCTON[®] is used for the RISE[®]/EMC and the SLIPSIL[®]/EMC systems.

DRIFIL[®] is a water-repellent sealant based on a single-component silicone compound. In developing DRIFIL[®] sealing compound, high priority was focused on its power of adhesion to substrates as occurring in the construction sector, and to cable sheathing and metal and plastic pipes. In addition, special attention was given to the permanent flexibility of the sealant in order to permit minor settlements and movements of the cable/pipe bunch after the sealant has set. The purpose of this is to ensure that the seal remains intact in the longer term even in spite of possible mechanical loading.

DRIFIL[®] sealant has a very short setting time. The top layer is rapidly tack-free.

FIWA[®] is a fire-resistant sealant based on a single component silicone compound. FIWA[®] is also water-repellent. The sealant adheres well to most substrates occurring in the building industry, and is permanently elastic. In the event of fire or at temperatures in excess of 200 °C the sealant expands to about five to ten times its original volume. During this process a porous mass is formed which has excellent thermal insulation properties. In contrast to conventional materials that swell under severe heat exposure, the expansion of FIWA[®] is not caused by intumescence, but by a chemical process. The advantage of this is that the expansion of FIWA[®] is not accompanied by the formation of fumes.



For ease of application of very high viscosity sealants, we have selected a powerful manual applicator with a 26 : 1 trigger leverage. This means much easier dispensing and reduced fatigue. The applicator is equipped with the so-called Wear Compensating Device, which automatically removes free-play in the trigger to provide instant rod drive immediately when the trigger is pulled. Less full trigger strokes required to empty a cartridge. Extended working life of the applicator.



We have also selected a powerful pneumatic applicator for highest productivity.

Quiet operation (less than 70 dB). Air supply to suit most standard systems. Fast, easy pressure regulation for accurate flow control. High volume trigger valve for immediate sealant flow. Ergonomic design: comfort, minimal operator fatigue. Short, well balanced design, combined with lightweight engineering plastic and aluminium components. Also available for 1 liter cartridges.

RISE[®] MULTI-CABLE TRANSITS: THE RAPID[®] SEALING SYSTEM

*ease of calculation with
RISE[®] cable and pipe penetrations*



TRANSIT CALCULATOR

**Calculate
your materials
requirements for our
fire safe and gas and
smoke tight sealing
systems**

**RISE
RISE/NOFIRNO
RISE/ULTRA
RISWAT
RIACNOF**

Free software. Can be downloaded from our website <http://www.rise-systems.com>.

After the entry of the dimensions of the conduit opening and the amount and outer diameters of the ducted cables or pipes, the software calculates the amount of RISE[®] or RIWAT[®] insert sleeves, the RISE[®], RISWAT[®] or NOFIRNO[®] filler sleeves, the ACTIFOAM[®] spare filling sheets, the RISE[®] or RISE[®]/ULTRA crushers and the DRIFIL[®], FIWA[®] or NOFIRNO[®] sealant.

It is easy to switch between the several systems and also between A-class, H-class, EMC and watertight penetrations.

After entry of the dimensions and amount and sizes of cables/pipes, a drawing appears on the screen showing also the remaining free space in the conduit opening. Furthermore the filling rate of the cable penetrations is shown.

Warnings appear for deviations of the certified configurations and for overfilling the transits or exceeding filling rates.

For a created project all calculated transits can be stored in a database. Order/calculation forms can be shown on screen for project totals and single transits. The material lists can be printed and/or exported to MS Word.

*we are there with full support for
RISE[®] cable and pipe penetrations*

ARTIST IMPRESSION OF THE FIRST PHASE OF THE NEW FACTORY NEXT TO OUR R&D CENTRE



- 1) machines specially developed for compounding and processing of rubbers under controlled conditions to obtain optimum quality
- 2) machines specially developed for compounding and manufacturing of all types of sealants under controlled processing
- 3) moisture treatment installation and processing equipment for manufacturing of electrically conductive sealants and rubbers
- 4) a complete line of injection moulding presses ranging from 40 tons up to 400 tons for manufacturing sealing plugs and other rubber components
- 5) a complete line of compression moulding presses up to 300 tons for manufacturing larger type sealing plugs and ULEPSI rubber plates
- 6) processing installation for after-curing of rubber products to obtain the required compression set (long term behaviour)
- 7) extruder line including cooling system and cutting and slitting installation for manufacturing insert and filler sleeves for the RISWAT system
- 8) fully automatic extruder lines with a length of 20 meters, including cooling system and automatic cutting, slitting and sorting installation for manufacturing rubber insert and filler sleeves and rubber strips of the RISE system
- 9) extruder line for manufacturing luminescent profiles and hoses
- 10) line of injection moulding machines ranging from 50 up to 200 tons for manufacturing plates of the ULEPSI tank supports and luminescent YFESTOS floor coverings
- 11) completely equipped die-making shop for the in-house production of all tooling for rubber and plastics manufacturing
- 12) modern laser equipment for engraving the type codes in the dyes for rubber manufacturing and for marking products with bar and 2D-matrix codes
- 13) mixing and airless spraying facilities for the NOFIRNO boards

*Together with highly advanced systems and technologies
we offer highest quality products.*



YOUR RELIABLE
PARTNERS





**MAXIMUM SIMPLICITY OF USE
OPTIMUM FLEXIBILITY
OUTSTANDING PERFORMANCE**

Websites: <http://www.actifoam.com>, www.beele.com, www.firsto.com, www.nofirno.com,
www.rise-systems.com, www.rise-nofirno.com, www.riswat.com and www.slipsil.com

ASK FOR THE SEPARATE BROCHURES ON OUR PRODUCT RANGES:

- * **RISE® MULTI-CABLE TRANSIT SYSTEM**
- * **RISE® SEALING SYSTEM FOR SINGLE AND MULTI-PIPE PENETRATIONS**
- * **RIACNOF® MULTI-CABLE TRANSIT SYSTEM**
- * **RISE®/NOFIRNO® MULTI-ALL-MIX CABLE AND PIPE TRANSITS**
- * **RISE®-ULTRA SINGLE PLASTIC PIPE PENETRATIONS**
- * **RISWAT® GAS AND WATERTIGHT CABLE AND PIPE DUCTS**
- * **SLIPSIL® SEALING PLUGS FOR PIPE ENTRIES**
- * **SLIPSIL®-SQ MULTI-CABLE TRANSITS**
- * **DYNATITE® DYNAMIC HIGH PRESSURE SEALS**
- * **BEESEAL® MULTI-PIPE AND CABLE PENETRATIONS**
- * **ACTIFOAM® TEMPORARY SEALS AND CAVITY SEALS**
- * **FIRSTO® FIRESTOPS FOR CABLE TRAY PENETRATIONS**
- * **NOFIRNO® CAVITY SEALS, COATINGS AND SEALANTS**
- * **ULEPSI® TANK SUPPORTS FOR BITUMEN TANKERS**





**CONDUIT SEALING DEVICES OF AN
AMAZING SIMPLICITY WITH AN
OUTSTANDING PERFORMANCE**



BEELE Engineering and CSD International have been involved with fire, water and gas tight sealing for more than 30 years. We have developed and tested products proven to provide the utmost in sealing protection around the world. To receive our complete civil construction and/or marine products catalogues, please contact your distributor or local representative.

distributed by:



BEELE Engineering bv - CSD International bv
Beunkdijk 11 - 7122 NZ AALTEN - THE NETHERLANDS
Tel. +31 543 461629 - Fax +31 543 461786 - E-mail: info@beele.com
Websites: <http://www.actifoam.com>, www.beele.com, www.csdplugs.com, www.firsto.com,
www.nofirno.com, www.rise-systems.com, www.riswat.com and www.slipsil.com

