

DYNATITE®

DYNAMIC SEALING SYSTEM FOR HIGH PRESSURE LOADS

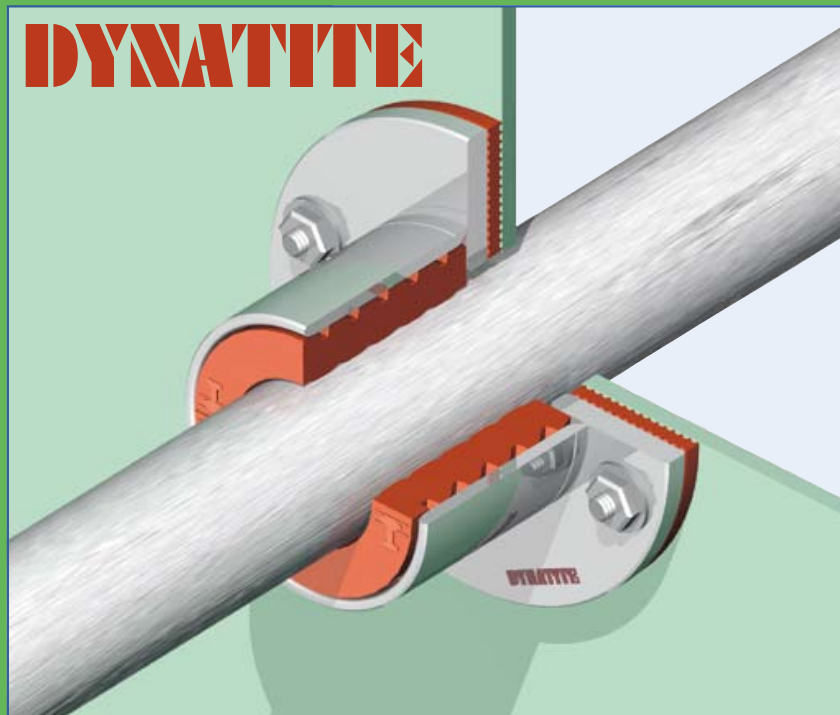

**DYNATITE® TECHNOLOGY:
EXTREMELY HIGH PRESSURE RATINGS
BY DYNAMIC SEALING UNDER
(INSTANTANEOUS) PRESSURE LOADS**





Copyright	: BEELE Engineering BV/CSD International BV, Aalten, the Netherlands. Proprietary rights on all drawings and technical data released in this brochure. © 1997-2010
Edition	: May 2010
Note	: No part of this publication may be reproduced without explicit written approval of BEELE Engineering BV.
Research & Development	: BEELE Engineering BV, Aalten, the Netherlands.
Note	: The manufacturer reserves the right to make dimensional and design modifications without prior notification.
®	: ACTIFIRE, ACTIFOAM, AQUASTOP, BEEBLOCK, BEELE, BEESEAL, CONDUCTION, CRUSHER, CSD, CSD THE SIMPLE SEAL SYSTEM, DRIFIL, DYNATITE, FIRSTO, FIWA, LEAXEAL, MULTI-ALL-MIX, NOFIRNO, RAPID TRANSIT SYSTEM, RIACNOF, RISE, RISWAT, ⚡ , SLIPSIL, flanges SLIPSIL plugs, ULEPSI and YFESTOS are registered trade marks of BEELE Engineering BV.
brochure code	: dynatite/hb/en/mar





WE CARE



BEELE ENGINEERING - SAFETY, RELIABILITY, INVOLVEMENT

Every moment of the day, in every business and every situation, the threat of fire is present. For over three decades, BEELE Engineering has specialized in passive fire safety in the form of systems which prevent the spread of fire, smoke, water and gases via cable and pipe penetrations. With our superior sealing technologies, we have become the undisputed Number One in this particular field.

It is BEELE Engineering's philosophy that R&D exists to respond to market demands. Only then can research and development activities be classed as functional. Only then are innovative solutions generated for problems that have current or near-term relevance. Our policy is one of continuous active response to customers' demands, or to modified or new functional requirements. We listen, we observe and we interpret, and so we arrive at new product developments and bold innovations.

BEELE Engineering has built up an enormous body of specialized expertise and knowledge. Our company is the world market leader in sealing systems for state-of-the-art shipbuilding applications as well as civil and industrial applications. We do not follow trends, we set them.

Development of new products and technologies, as well as pioneering know-how, are present in every fibre of our organization. We are driven by passion for our specialization, and our customer involvement drives us to exceed the boundaries of what is technically feasible.

BEELE Engineering operates world-wide. From our agencies in virtually every industrialized country, our support and services are always somewhere nearby. We are there for you – also for on-site advice or in-house demonstrations, instructions and support at your location.



Our development, test and production facilities are among the most advanced in the world. The factory is equipped with state of the art machines, which are tailor made to the requirements of our company. We work to a high-level ISO system, with unmatched involvement. Continuous investment in design technologies, combined with highest quality polymers, is our guarantee for the safety of lives and equipment. That is why BEELE Engineering is internationally recognized by all relevant certification institutes and classification societies.



GENERAL
Marine
SERVICES

156 Beaumont Street · Westhaven · Auckland · New Zealand

Sales Ph +64 9 309 0048 · sales@generalmarine.co.nz

Service Ph +64 9 368 0938 · service@generalmarine.co.nz

www.generalmarine.co.nz



DYNATITE® DYNAMIC SEALING SYSTEM FOR PIPE/CABLE ENTRIES

DYNATITE® dynamic sealing system has been developed especially for those applications where a high degree of (instantaneous) tightness is required and, for all, to maintain this performance on long term. The basics of the LEAXEAL®, NOFIRNO® and SLIPSIL® technology have been combined in the development of a pipe and cable transit sealing system which is easy to install, less vulnerable than any comparable system, maintenance friendly and without showing any degradation during service life.

The resulting DYNATITE® technology stands for dynamic tightness enabled by excellent rubber design of the sealing plugs and high-tech conduit sleeves.



The system is primarily suitable for all situations in which a sudden pressure exposure can occur. The objective is not only to hold multi-cable and pipe transits in situ, but also completely tight. Reference is made to the Thunder Horse

incident on which compressive sealing systems dramatically failed during water ingress. Accidents have their own time frame and at that exact moment the systems have to function. There are numerous other occasions where disasters such as flooding and explosions could create substantial damage when sealing systems would fail. In such "explosive" situations, the sealing system will be exposed to an instantaneous pressure load and should therefore be able to settle itself rather quick. DYNATITE® is such a dynamic sealing system. Since rubber is incompressible, only an

optimized profiling of the rubber parts can fulfil this requirement. A further objective of the development is to avoid large numbers of contact surfaces between rubber parts. The rubber polymer used should be able to reset itself when the pressure load disappears.

To allow dynamic sealing, the flange of the DYNATITE® plug fits inside the conduit sleeve. A retainer ring with engineered dimensions is positioned inside or against the back of the conduit sleeve in such a way that the flange of

the DYNATITE® plug is flush with the front side of the DYNATITE® conduit sleeve. The retainer ring functions as a stop for the sealing plug, which allows compression. The inner surface of the conduit opening is for such applications of utmost importance. For this reason, the DYNATITE® conduit sleeves are milled from stainless steel to precise dimensions. The sleeves are passivated and have inside a ceramic or PTFE coating. Corrosion is avoided and a smooth surface to maintain gliding properties of the rubber during service life is guaranteed.

Specially developed for application in the columns of semi-submersible rigs, the system can be used in many other hazardous areas such as blast walls, explosion proof areas, subsea applications and all those situations where a (sudden) substantial pressure might arise.

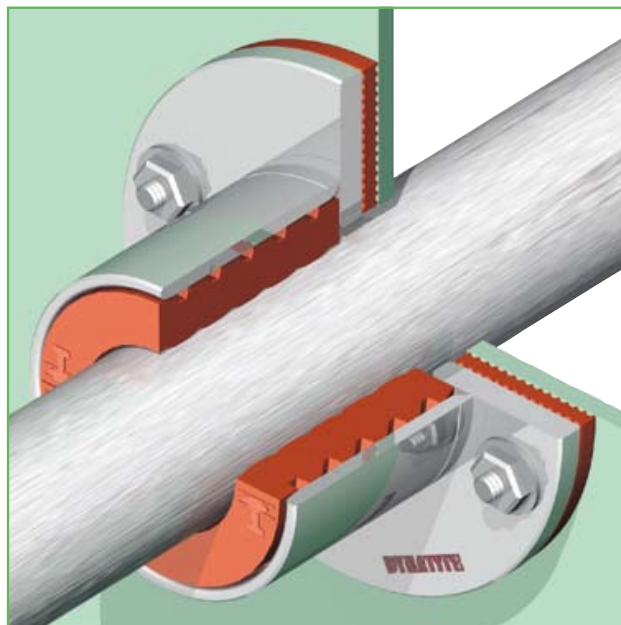

DYNATITE

WE CARE

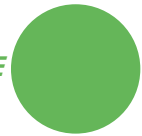

**DYNATITE® DYNAMIC SEALING SYSTEM
FOR PIPE/CABLE ENTRIES**



The new test vessel in the R&D centre suitable for pressures up to 15 bar. The unit has been inspected by Bureau Veritas during the entire manufacturing process.



GENERAL
Marine
SERVICES

156 Beaumont Street · Westhaven · Auckland · New Zealand
Sales Ph +64 9 309 0048 · sales@generalmarine.co.nz
Service Ph +64 9 368 0938 · service@generalmarine.co.nz

www.generalmarine.co.nz



DYNATITE

**DYNATITE® DYNAMIC SEALING SYSTEM
FOR PIPE/CABLE ENTRIES**

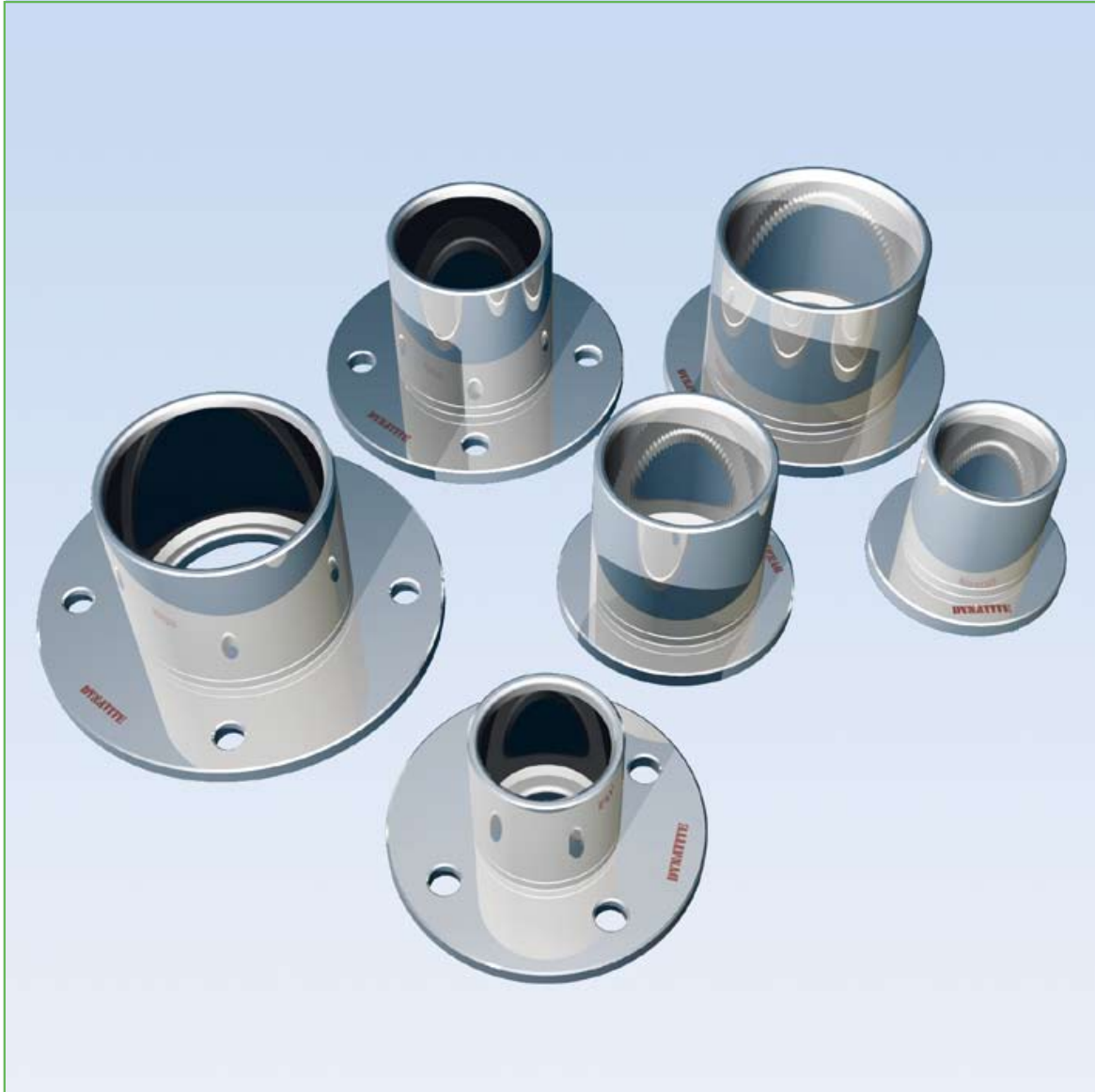

The conduit sleeves are milled to exact internal dimensions from stainless steel 1.4571. The milled sleeves are CDW seam welded to the flanges used for bolting or welding. To optimize corrosion resistance, especially for use in salt water conditions and harsh environments, the DYNATITE® conduit sleeves are surface treated on the basis of a unique passivation process. This prevents corrosion for a service life up to 15 years. The inner walls of the conduit sleeves for welding (right side) are treated with a silicon dioxide ceramic coating (500° C resistant, fire resistant); the inner walls of the conduit sleeves for bolting have a black PTFE coating.



GENERAL
Marine
SERVICES

156 Beaumont Street · Westhaven · Auckland · New Zealand
Sales Ph +64 9 309 0048 · sales@generalmarine.co.nz
Service Ph +64 9 368 0938 · service@generalmarine.co.nz

www.generalmarine.co.nz

DYNATITE

WE CARE



**DYNATITE® DYNAMIC SEALING SYSTEM
FOR PIPE/CABLE ENTRIES**



The NOFIRNO® rubber, used for the plugs and gaskets, has excellent weathering properties, UV and ozone resistance and long term behaviour. Service life easily exceeds 50 years under normal environmental conditions. The rubber can be used in a very wide temperature range. Even at low temperatures down to -50° C the rubber stays flexible. This guarantees tightness even at low temperatures.

NOFIRNO® rubber is made of a high grade, inert silicone polymer.

The NOFIRNO® gaskets have a special profiling to exclude the need for excessive compression and the need for retightening from time to time.



GENERAL
Marine
SERVICES

156 Beaumont Street · Westhaven · Auckland · New Zealand

Sales Ph +64 9 309 0048 · sales@generalmarine.co.nz

Service Ph +64 9 368 0938 · service@generalmarine.co.nz

www.generalmarine.co.nz



DYNATITE

**DYNATITE® DYNAMIC SEALING SYSTEM
FOR PIPE/CABLE ENTRIES**

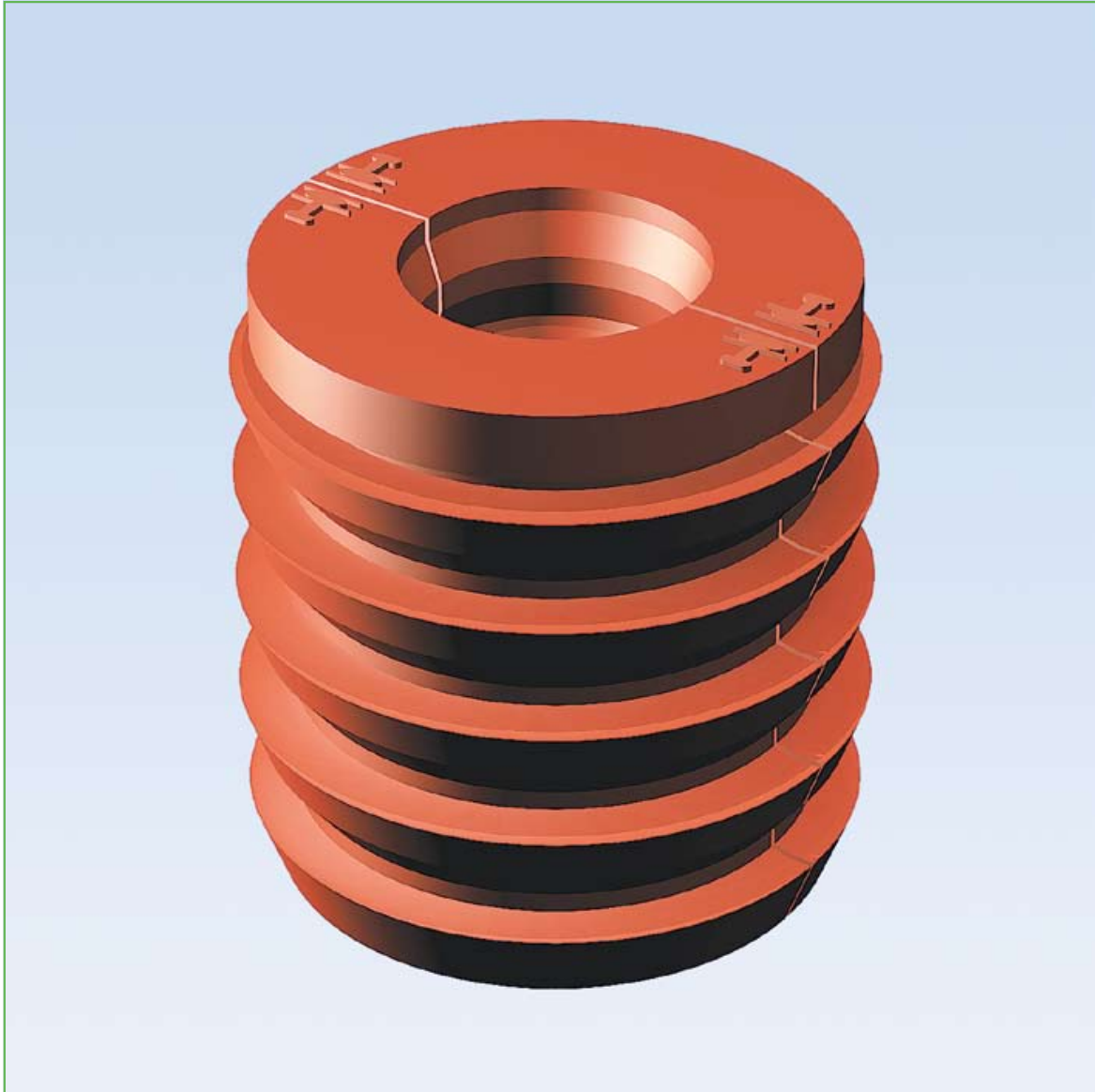

In view of the incompressibility of rubbers, the design work focused on finding an ideal solution to allow rubber to move in the right directions under mechanical loads. To cope with instantaneous pressure loads, an ultimate displacement of the rubber is needed. For this reason, the flange has been designed to enable functioning as a guidance for the movement inside the conduit sleeve. The DYNATITE® plugs have a flange which has the same outer dimensions as the inside diameter of the conduit sleeve. By allowing displacement of the rubber, the initial labyrinth seal of the profiling without pressure load is then automatically improving to cope with higher ratings.



GENERAL
Marine
SERVICES

156 Beaumont Street · Westhaven · Auckland · New Zealand
Sales Ph +64 9 309 0048 · sales@generalmarine.co.nz
Service Ph +64 9 368 0938 · service@generalmarine.co.nz

www.generalmarine.co.nz

DYNATITE

WE CARE



DYNATITE® DYNAMIC SEALING SYSTEM FOR PIPE/CABLE ENTRIES



The DYNATITE® dynamic sealing system is developed for harshest conditions. For this reason it has to be an integrated system, composed of conduit sleeves and sealing plugs (and where appropriate with gaskets). Exact dimensions and corrosion proof conduit sleeves are a must. Most important is the long term performance of the rubber grade of the plugs and gaskets. The NOFIRNO® rubber, used for the plugs and gaskets, has excellent weathering properties, UV and ozone resistance and long term behaviour. Service life easily exceeds 50 years under normal environmental conditions. On the basis of all these properties DYNATITE® is a unique system.



GENERAL
Marine
SERVICES

156 Beaumont Street · Westhaven · Auckland · New Zealand
Sales Ph +64 9 309 0048 · sales@generalmarine.co.nz
Service Ph +64 9 368 0938 · service@generalmarine.co.nz

www.generalmarine.co.nz



DYNATITE

**DYNATITE® DYNAMIC SEALING SYSTEM
FOR PIPE/CABLE ENTRIES**

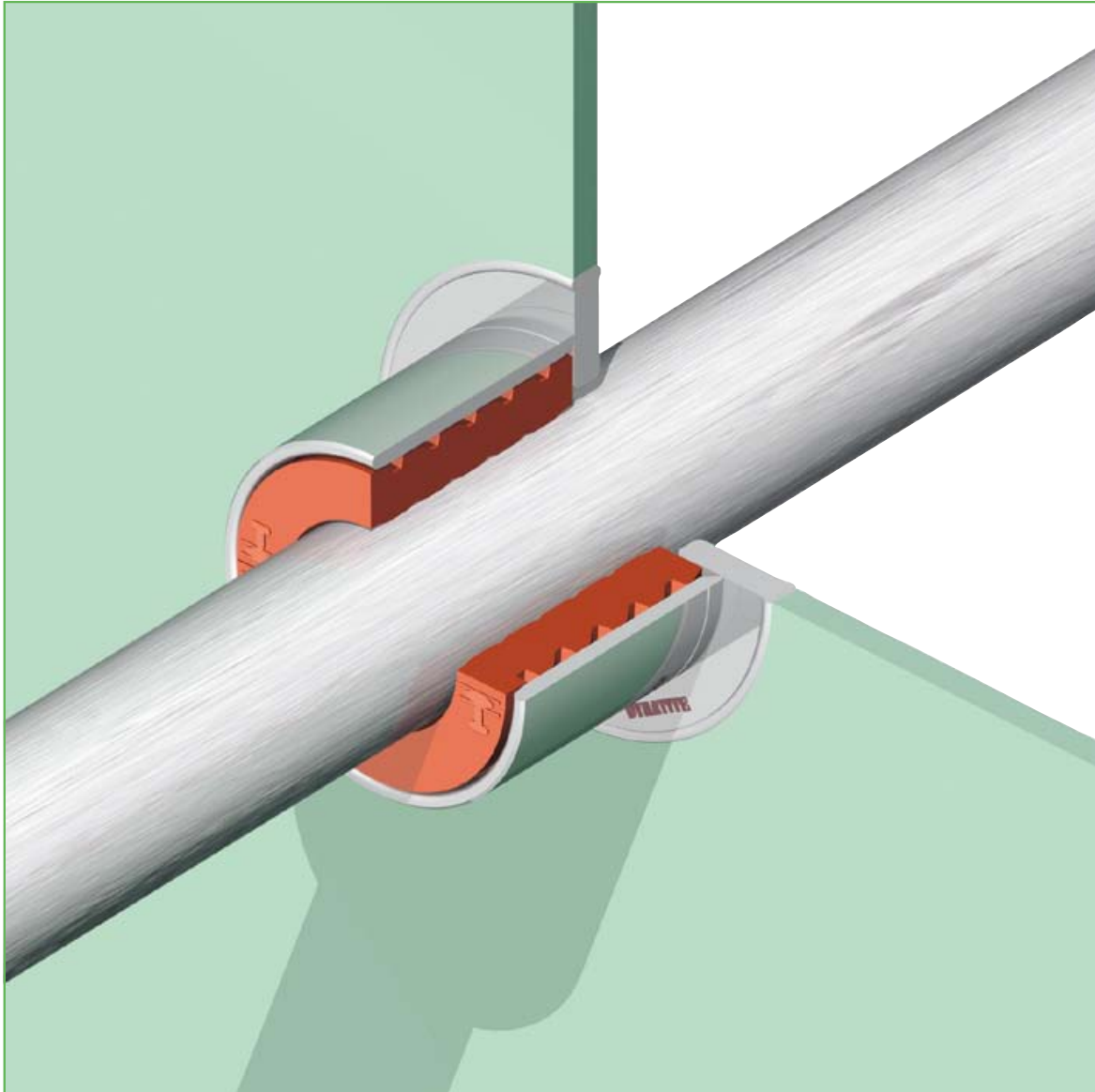

Especially developed for application in the columns of semi-submersible rigs, the system can be used in many other hazardous areas such as blast walls, explosion proof areas, subsea applications and all those situations where a (sudden) substantial pressure might arise.

For new installations, the DYNATITE® conduit sleeves can be welded into the partition. The flange has a thickness of 8 mm. The width of the flange is such that the ceramic coating inside the conduit sleeve is not affected by the welding heat.



GENERAL
Marine
SERVICES

156 Beaumont Street · Westhaven · Auckland · New Zealand
Sales Ph +64 9 309 0048 · sales@generalmarine.co.nz
Service Ph +64 9 368 0938 · service@generalmarine.co.nz

www.generalmarine.co.nz

DYNATITE

WE CARE



**DYNATITE® DYNAMIC SEALING SYSTEM
FOR PIPE/CABLE ENTRIES**

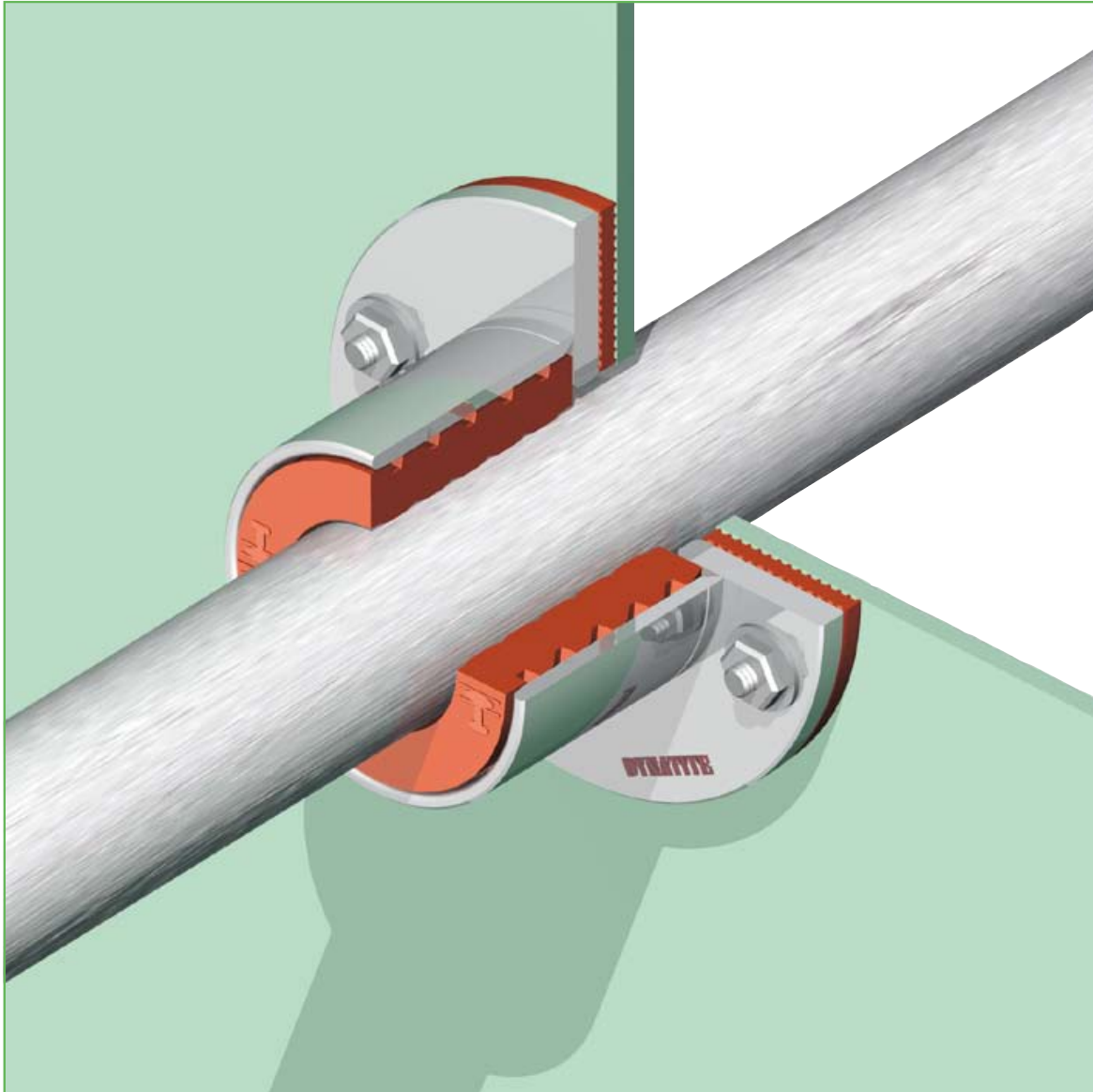

For existing installations, DYNATITE® conduit sleeves, which can be bolted to the partition, are supplied. These conduit sleeves can also be used to concrete walls in onshore installations. Since the conduit sleeves are ready for use and therefore don't have to be exposed to any welding heat, the inside of the conduit sleeve could be treated with a PTFE coating to improve the gliding properties even more compared to the ceramic coated welding sleeves.



GENERAL
Marine
SERVICES

156 Beaumont Street · Westhaven · Auckland · New Zealand
Sales Ph +64 9 309 0048 · sales@generalmarine.co.nz
Service Ph +64 9 368 0938 · service@generalmarine.co.nz

www.generalmarine.co.nz



DYNATITE

**DYNATITE® DYNAMIC SEALING SYSTEM
FOR PIPE/CABLE ENTRIES**

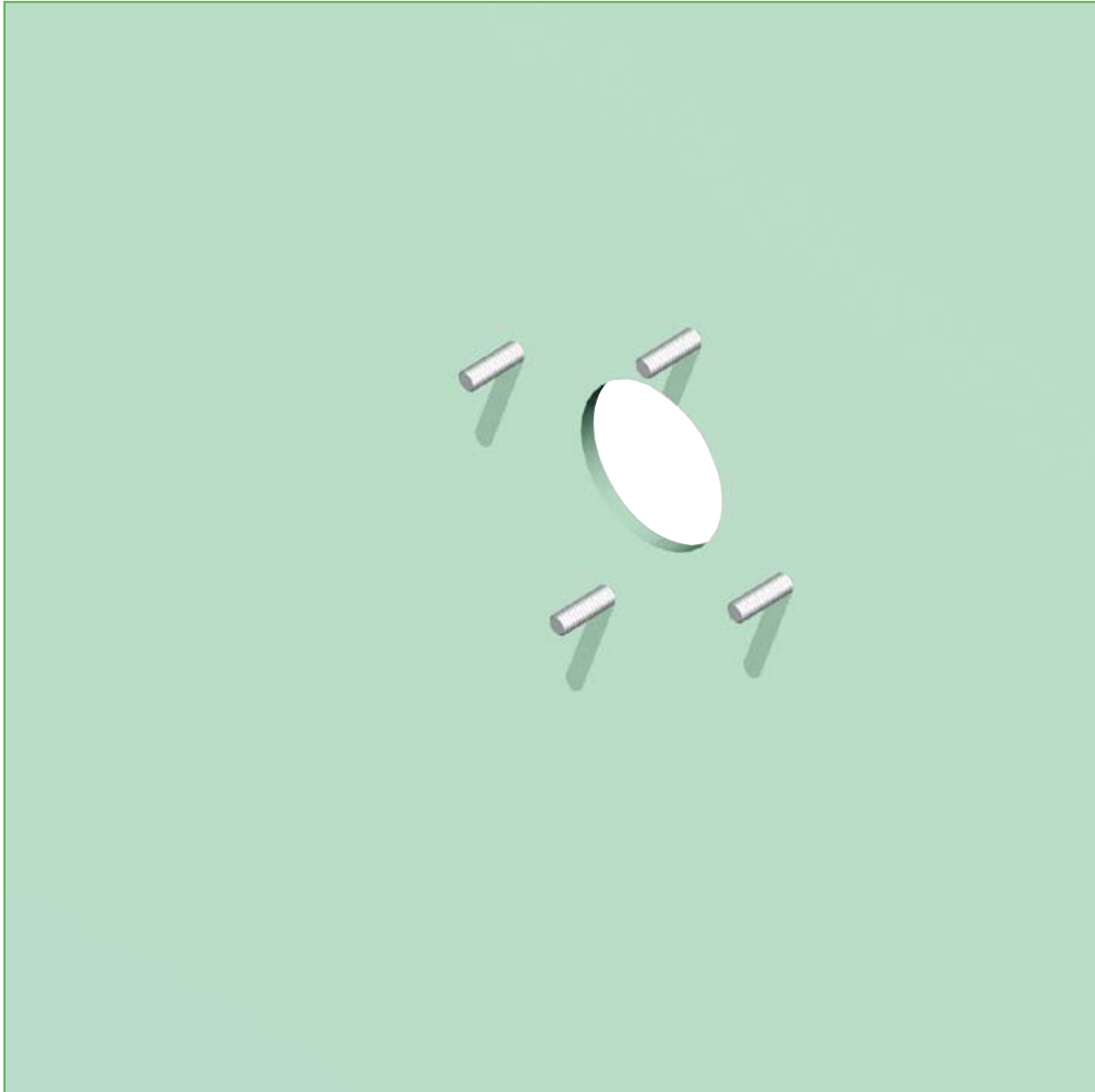

1) When DYNATITE® conduit sleeves for bolting are going to be used, a hole has to be cut in the partition to the size of the opening in the retainer flange of the DYNATITE® conduit sleeve. Threaded ends have to be welded to the partition in accordance with the hole configuration of the flange of the conduit sleeve. In case of application against concrete walls, stainless steel anchor bolts should be used.



GENERAL
Marine
SERVICES

156 Beaumont Street · Westhaven · Auckland · New Zealand
Sales Ph +64 9 309 0048 · sales@generalmarine.co.nz
Service Ph +64 9 368 0938 · service@generalmarine.co.nz

www.generalmarine.co.nz

DYNATITE

WE CARE



**DYNATITE® DYNAMIC SEALING SYSTEM
FOR PIPE/CABLE ENTRIES**



2) A fitting NOFIRNO® gasket is placed over the threaded ends against the partition.



GENERAL
Marine
SERVICES

156 Beaumont Street · Westhaven · Auckland · New Zealand

Sales Ph +64 9 309 0048 · sales@generalmarine.co.nz

Service Ph +64 9 368 0938 · service@generalmarine.co.nz

www.generalmarine.co.nz



DYNATITE

**DYNATITE® DYNAMIC SEALING SYSTEM
FOR PIPE/CABLE ENTRIES**



3) The DYNATITE® conduit sleeve can then be positioned and fixed to the partition. Avoid excessive forces on tightening to maintain the flexibility of the NOFIRNO® gasket and to guarantee tightness on long term.



GENERAL
Marine
SERVICES

156 Beaumont Street · Westhaven · Auckland · New Zealand
Sales Ph +64 9 309 0048 · sales@generalmarine.co.nz
Service Ph +64 9 368 0938 · service@generalmarine.co.nz

www.generalmarine.co.nz

DYNATITE

WE CARE



**DYNATITE® DYNAMIC SEALING SYSTEM
FOR PIPE/CABLE ENTRIES**

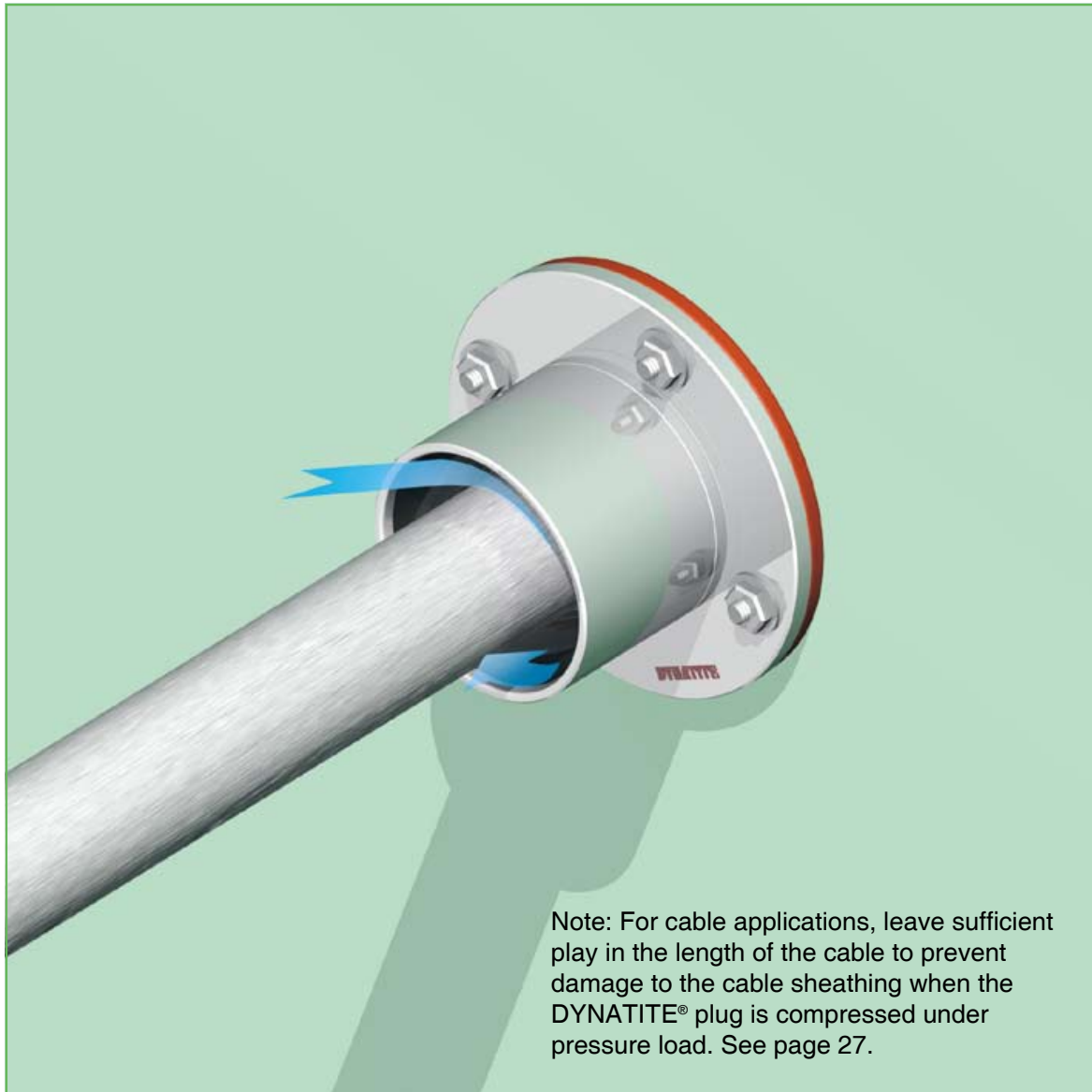

Note: For cable applications, leave sufficient play in the length of the cable to prevent damage to the cable sheathing when the DYNATITE® plug is compressed under pressure load. See page 27.

4) Once the DYNATITE® conduit sleeve is fixed against the partition, the pipe/cable can be passed through. The pipe/cable has to be ducted straight and centrally. This is of utmost importance for the displacement of the rubber when the pressure load occurs. Before starting the installation procedure, any dirt or oil residues should be removed from the conduit sleeve. The inside wall of the conduit sleeve is treated with CSD® lubricant to make installation of the DYNATITE® plug most easy.



GENERAL
Marine
SERVICES

156 Beaumont Street · Westhaven · Auckland · New Zealand
Sales Ph +64 9 309 0048 · sales@generalmarine.co.nz
Service Ph +64 9 368 0938 · service@generalmarine.co.nz

www.generalmarine.co.nz



WE CARE

DYNATITE

DYNATITE® DYNAMIC SEALING SYSTEM FOR PIPE/CABLE ENTRIES



5) The inside surfaces of both segments of the DYNATITE® sealing plug are then lubricated with CSD® lubricant. Also the flat contact surfaces of the plug halves should be lubricated to enable equal insertion in the conduit sleeve.

CSD® lubricant is acid free.

For selecting the right sealing plug, look for the plug series and the plug type in this series on the basis of the ID of the sleeve and the OD of the ducted pipe/cable. See page 31.



GENERAL
Marine
SERVICES

156 Beaumont Street · Westhaven · Auckland · New Zealand

Sales Ph +64 9 309 0048 · sales@generalmarine.co.nz

Service Ph +64 9 368 0938 · service@generalmarine.co.nz

www.generalmarine.co.nz

DYNATITE

WE CARE



**DYNATITE® DYNAMIC SEALING SYSTEM
FOR PIPE/CABLE ENTRIES**



6) The segments of the DYNATITE® sealing plug are also treated with CSD® lubricant on the outside.
Please refer to the Safety Data Sheet of the CSD® lubricant for more information.



GENERAL
Marine
SERVICES

156 Beaumont Street · Westhaven · Auckland · New Zealand
Sales Ph +64 9 309 0048 · sales@generalmarine.co.nz
Service Ph +64 9 368 0938 · service@generalmarine.co.nz

www.generalmarine.co.nz



DYNATITE

**DYNATITE® DYNAMIC SEALING SYSTEM
FOR PIPE/CABLE ENTRIES**

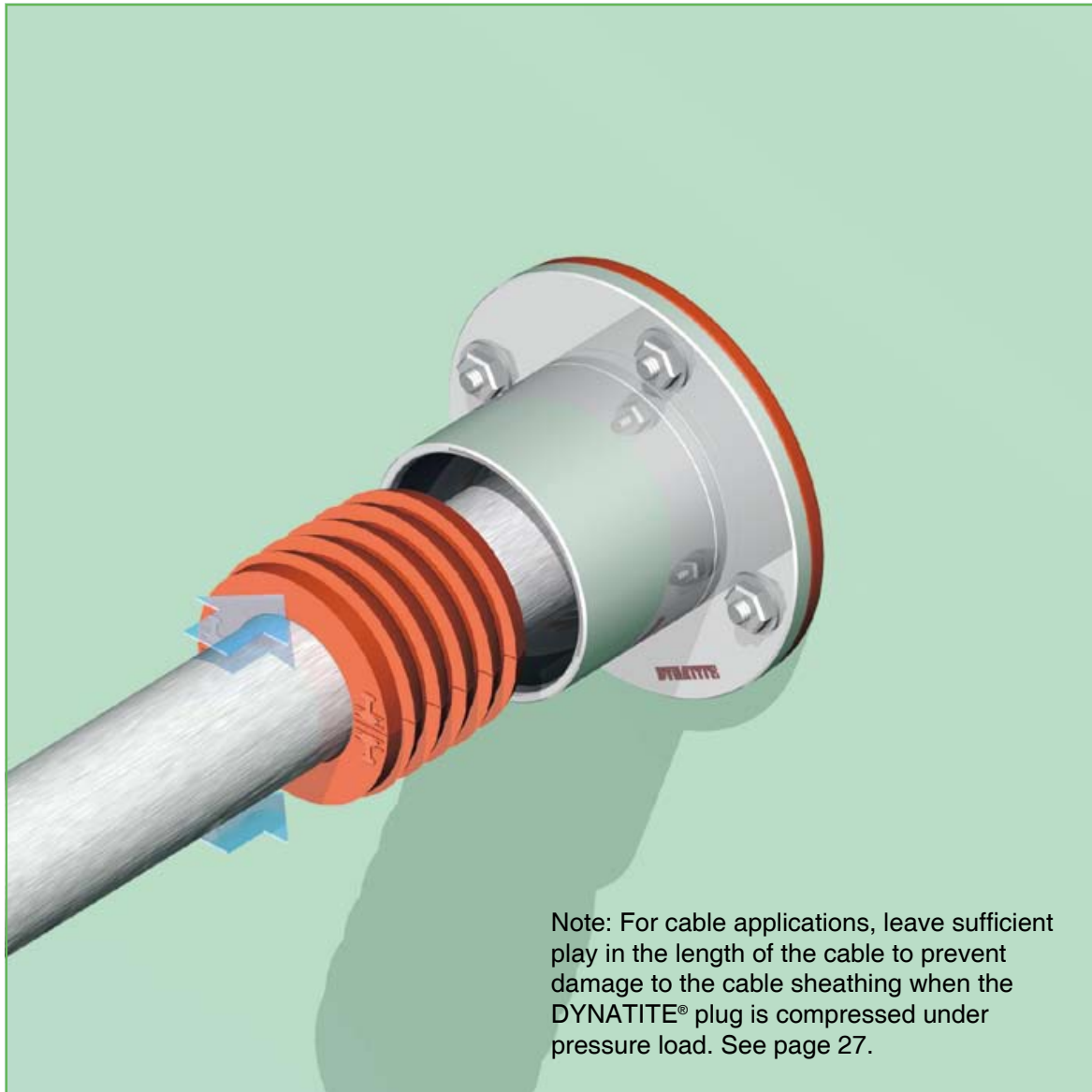

Note: For cable applications, leave sufficient play in the length of the cable to prevent damage to the cable sheathing when the DYNATITE® plug is compressed under pressure load. See page 27.

7) Both segments of the DYNATITE® sealing plug are placed around the ducted pipe/ cable, then pushed into the conduit sleeve as far as the first serration. The first serration is smaller than the other serrations to make this procedure very easy. Both halves are then pushed by hand evenly, further into the DYNATITE® conduit sleeve. The inlet of the DYNATITE® conduit sleeve is rounded off to avoid any damages to the plug during insertion.



GENERAL
Marine
SERVICES

156 Beaumont Street · Westhaven · Auckland · New Zealand
Sales Ph +64 9 309 0048 · sales@generalmarine.co.nz
Service Ph +64 9 368 0938 · service@generalmarine.co.nz

www.generalmarine.co.nz

DYNATITE

WE CARE



**DYNATITE® DYNAMIC SEALING SYSTEM
FOR PIPE/CABLE ENTRIES**

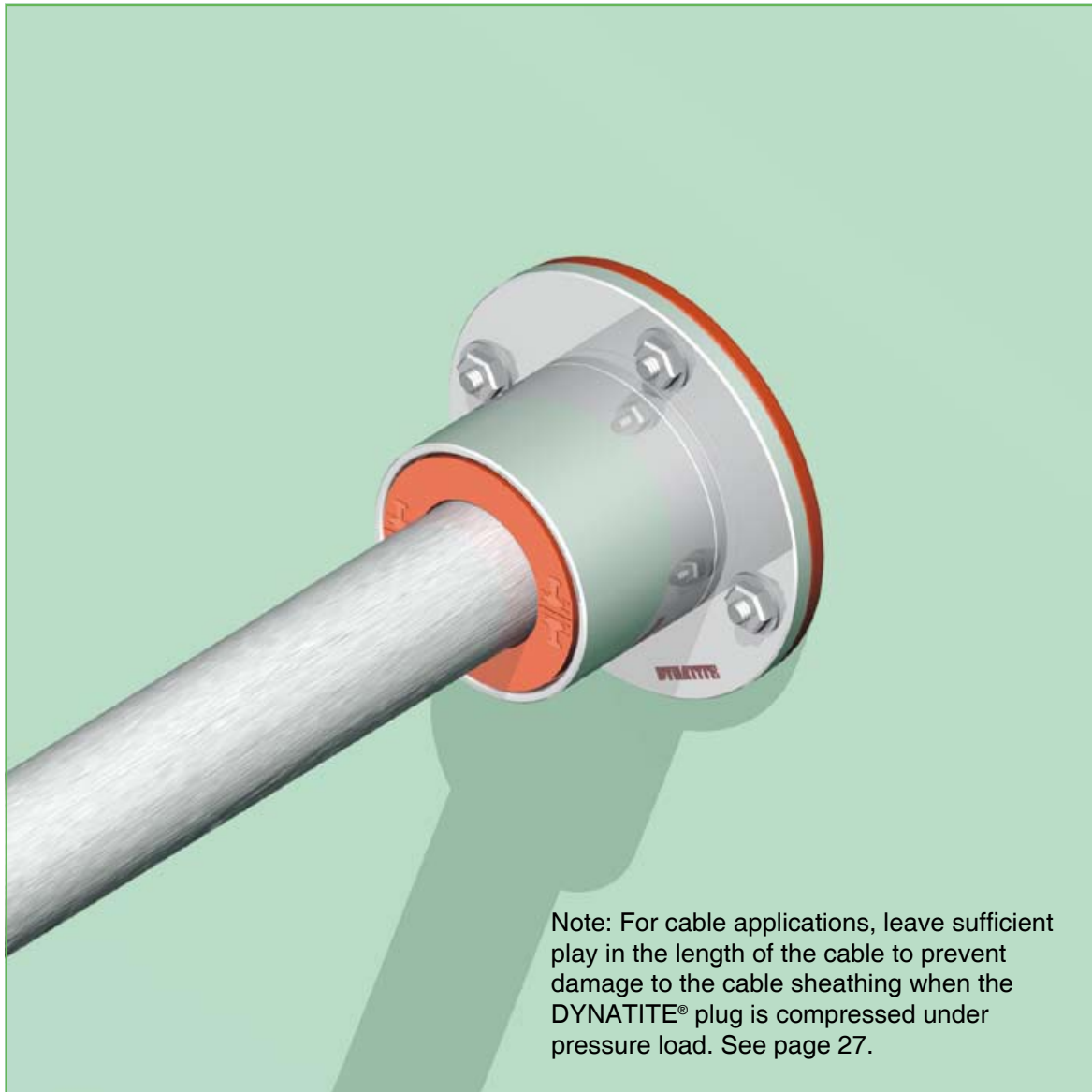

Note: For cable applications, leave sufficient play in the length of the cable to prevent damage to the cable sheathing when the DYNATITE® plug is compressed under pressure load. See page 27.

8) The front side of the DYNATITE® sealing plug must be flush with the front side of the DYNATITE® conduit sleeve. This proves that the back side of the plug is positioned against the retainer flange of the conduit sleeve. For horizontal ducts of heavy pipes/cables, it is extremely important to support the pipe/cable properly at both sides of the conduit. The DYNATITE® sealing system is a safety device. For inspection purposes, the allowed dimensions of the ducted pipe/cable are indicated on the flange of the plug.



GENERAL
Marine
SERVICES

156 Beaumont Street · Westhaven · Auckland · New Zealand
Sales Ph +64 9 309 0048 · sales@generalmarine.co.nz
Service Ph +64 9 368 0938 · service@generalmarine.co.nz

www.generalmarine.co.nz



DYNATITE

**DYNATITE® DYNAMIC SEALING SYSTEM
FOR PIPE/CABLE ENTRIES**

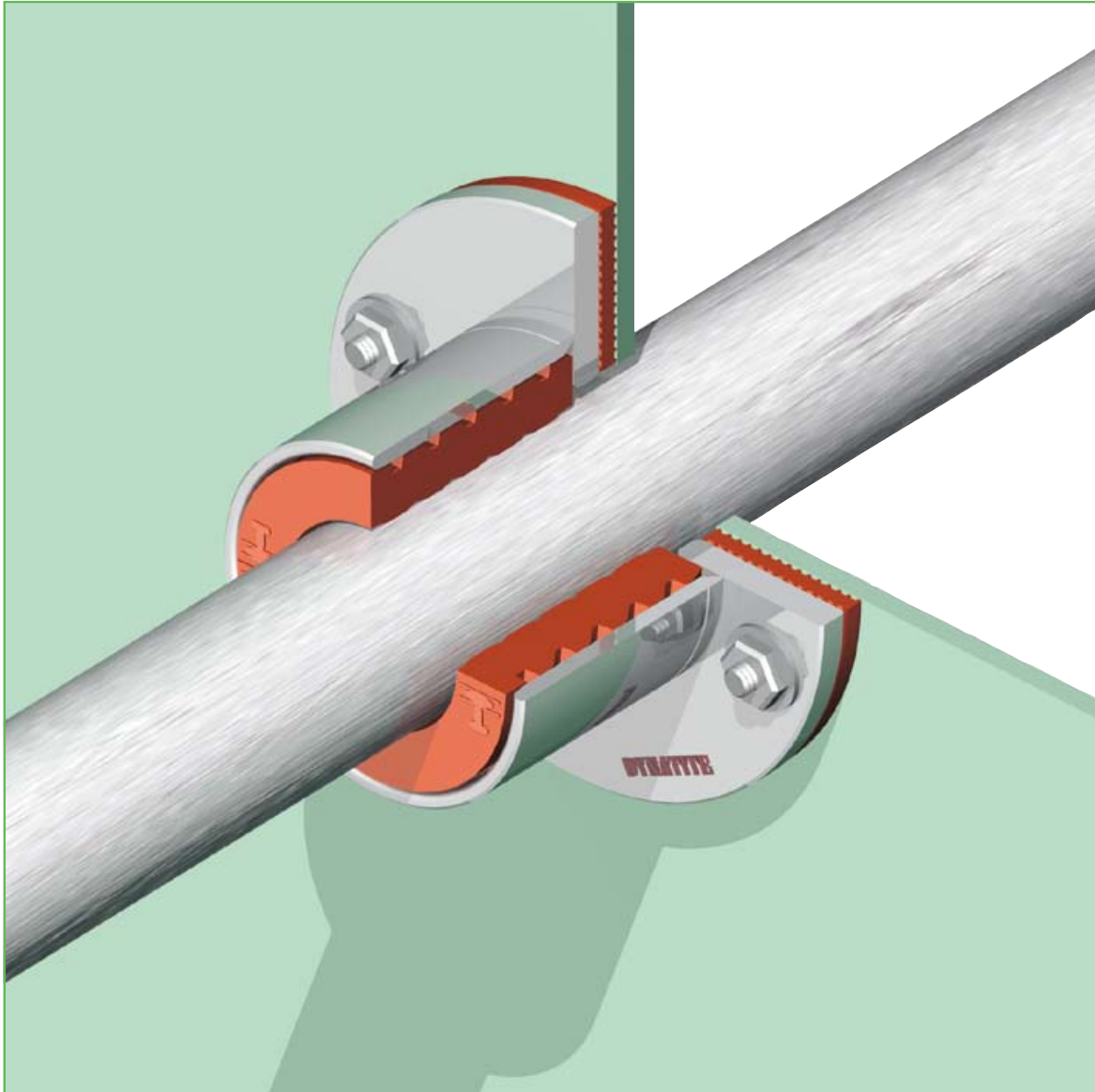

9) The DYNATITE® system has to be installed with its face on the side of the boundary that will be exposed to pressure. Otherwise the activation of the compression of the plug under pressure load is not feasible. For pressure loads from both sides, DYNATITE® conduit sleeves must be applied at both sides of the partition. The opening in the retainer flange has been dimensioned such that the use of plugs with a very thin wall thickness is prevented and also to have sufficient backing to hold the plug in place. All corners are rounded off to avoid any damage.



GENERAL
Marine
SERVICES

156 Beaumont Street · Westhaven · Auckland · New Zealand
Sales Ph +64 9 309 0048 · sales@generalmarine.co.nz
Service Ph +64 9 368 0938 · service@generalmarine.co.nz

www.generalmarine.co.nz

DYNATITE

WE CARE



**DYNATITE® DYNAMIC SEALING SYSTEM
FOR PIPE/CABLE ENTRIES**

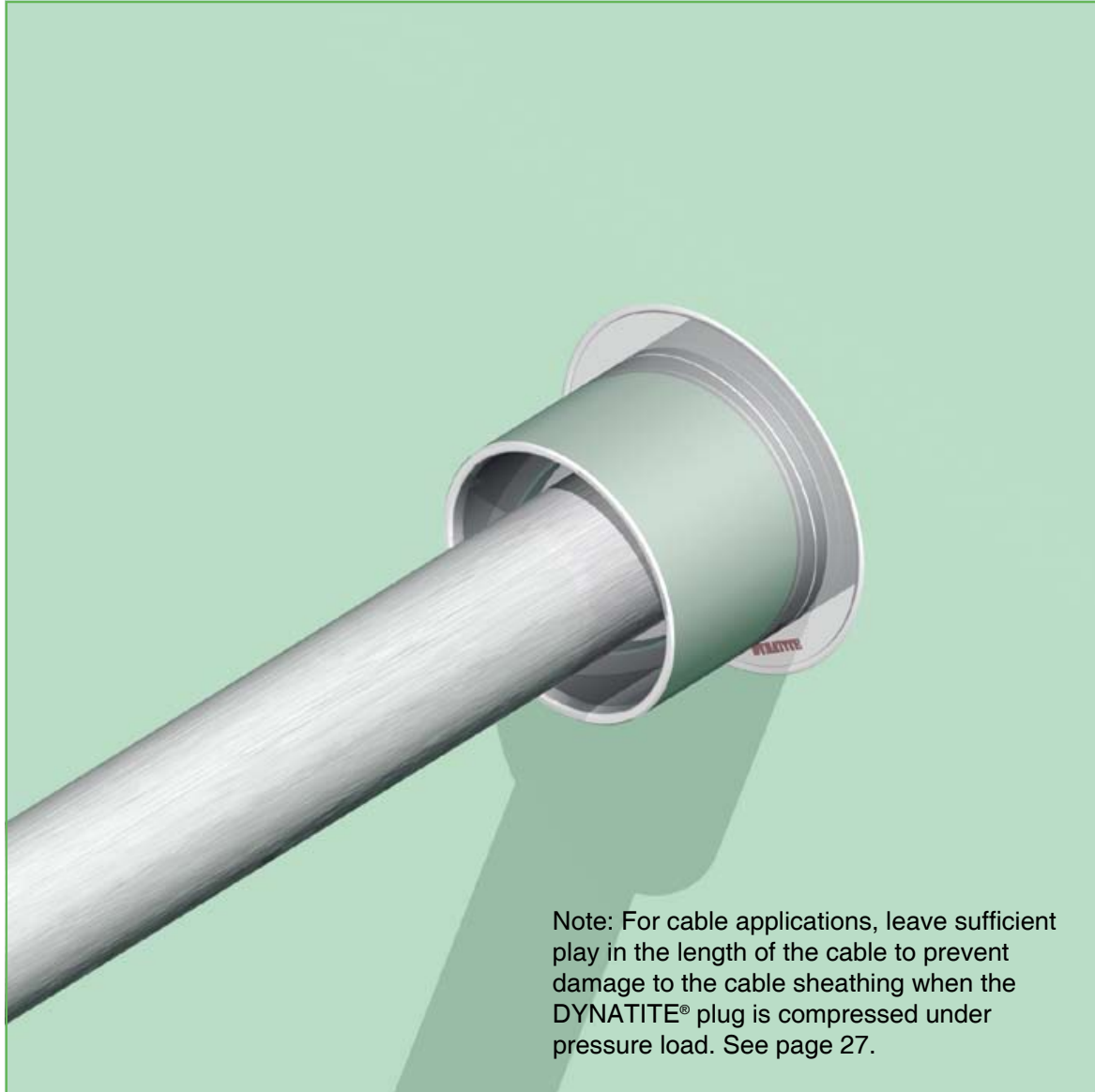

Note: For cable applications, leave sufficient play in the length of the cable to prevent damage to the cable sheathing when the DYNATITE® plug is compressed under pressure load. See page 27.

1) During welding, care has to be taken that no welding spots will get on the coated inner surface of the conduit sleeve. This would have an impact on the functionality of the system. Once the DYNATITE® conduit sleeve is welded into the partition, the pipe/cable can be passed through. The pipe/cable has to be ducted straight and centrally. This is of utmost importance for the displacement of the rubber when the pressure load occurs.



GENERAL
Marine
SERVICES

156 Beaumont Street · Westhaven · Auckland · New Zealand
Sales Ph +64 9 309 0048 · sales@generalmarine.co.nz
Service Ph +64 9 368 0938 · service@generalmarine.co.nz

www.generalmarine.co.nz



DYNATITE

**DYNATITE® DYNAMIC SEALING SYSTEM
FOR PIPE/CABLE ENTRIES**

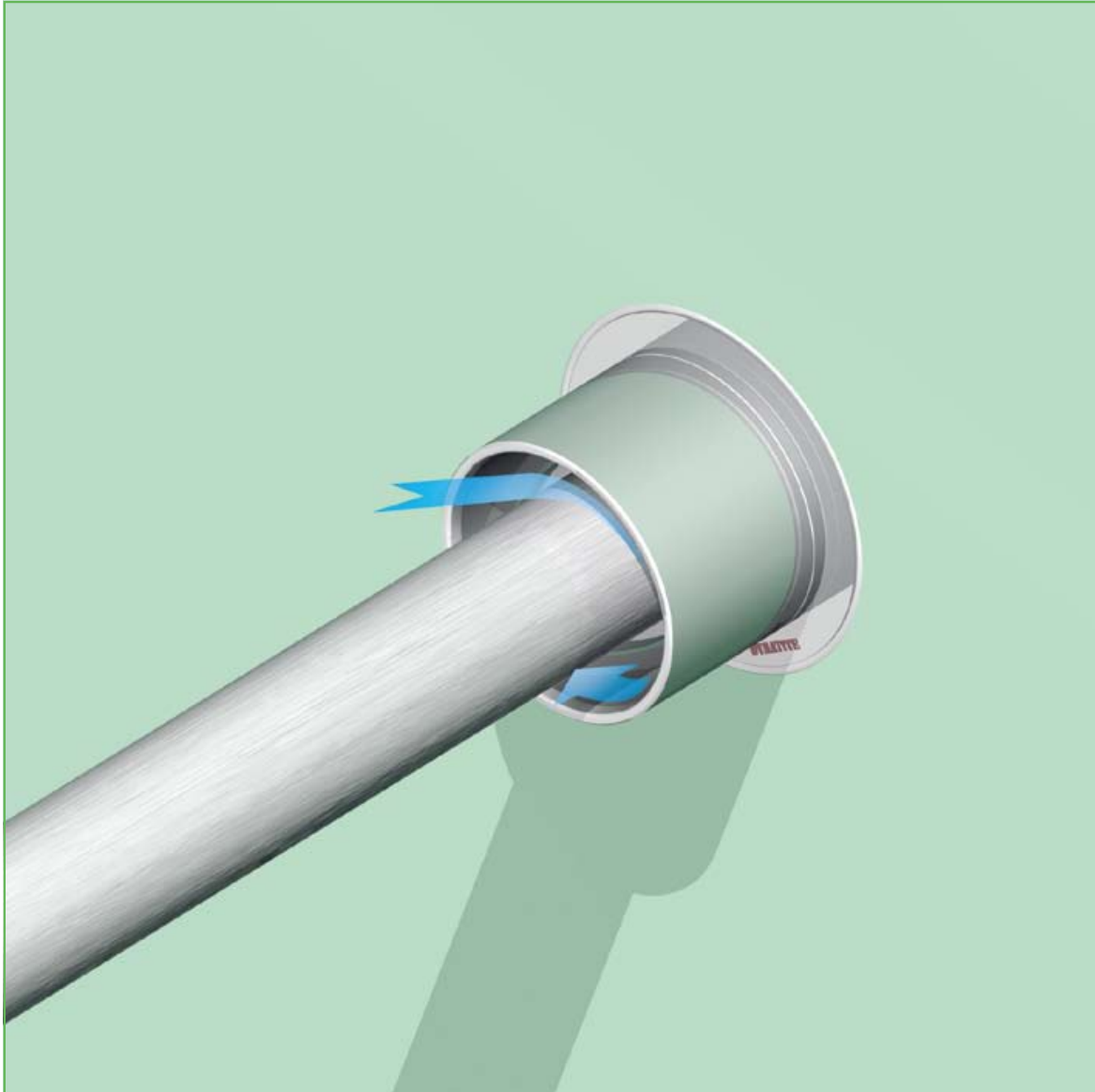

2) Before starting the installation procedure, any dirt or oil residues should be removed from the conduit sleeve. The inside wall of the conduit sleeve is treated with CSD® lubricant to make installation of the DYNATITE® plug most easy.



GENERAL
Marine
SERVICES

156 Beaumont Street · Westhaven · Auckland · New Zealand
Sales Ph +64 9 309 0048 · sales@generalmarine.co.nz
Service Ph +64 9 368 0938 · service@generalmarine.co.nz

www.generalmarine.co.nz

DYNATITE

WE CARE



**DYNATITE® DYNAMIC SEALING SYSTEM
FOR PIPE/CABLE ENTRIES**



3) The inside surfaces of both segments of the DYNATITE® sealing plug are then lubricated with CSD® lubricant. Also the flat contact surfaces of the plug halves should be lubricated to enable equal insertion in the conduit sleeve.

CSD® lubricant is acid free.

For selecting the right sealing plug, look for the plug series and the plug type in this series on the basis of the ID of the sleeve and the OD of the ducted pipe/cable.

See page 31.



GENERAL
Marine
SERVICES

156 Beaumont Street · Westhaven · Auckland · New Zealand

Sales Ph +64 9 309 0048 · sales@generalmarine.co.nz

Service Ph +64 9 368 0938 · service@generalmarine.co.nz

www.generalmarine.co.nz



DYNATITE

**DYNATITE® DYNAMIC SEALING SYSTEM
FOR PIPE/CABLE ENTRIES**



4) The segments of the DYNATITE® sealing plug are also treated with CSD® lubricant on the outside.
Please refer to the Safety Data Sheet of the CSD® lubricant for more information.



GENERAL
Marine
SERVICES

156 Beaumont Street · Westhaven · Auckland · New Zealand
Sales Ph +64 9 309 0048 · sales@generalmarine.co.nz
Service Ph +64 9 368 0938 · service@generalmarine.co.nz

www.generalmarine.co.nz

DYNATITE

WE CARE



**DYNATITE® DYNAMIC SEALING SYSTEM
FOR PIPE/CABLE ENTRIES**

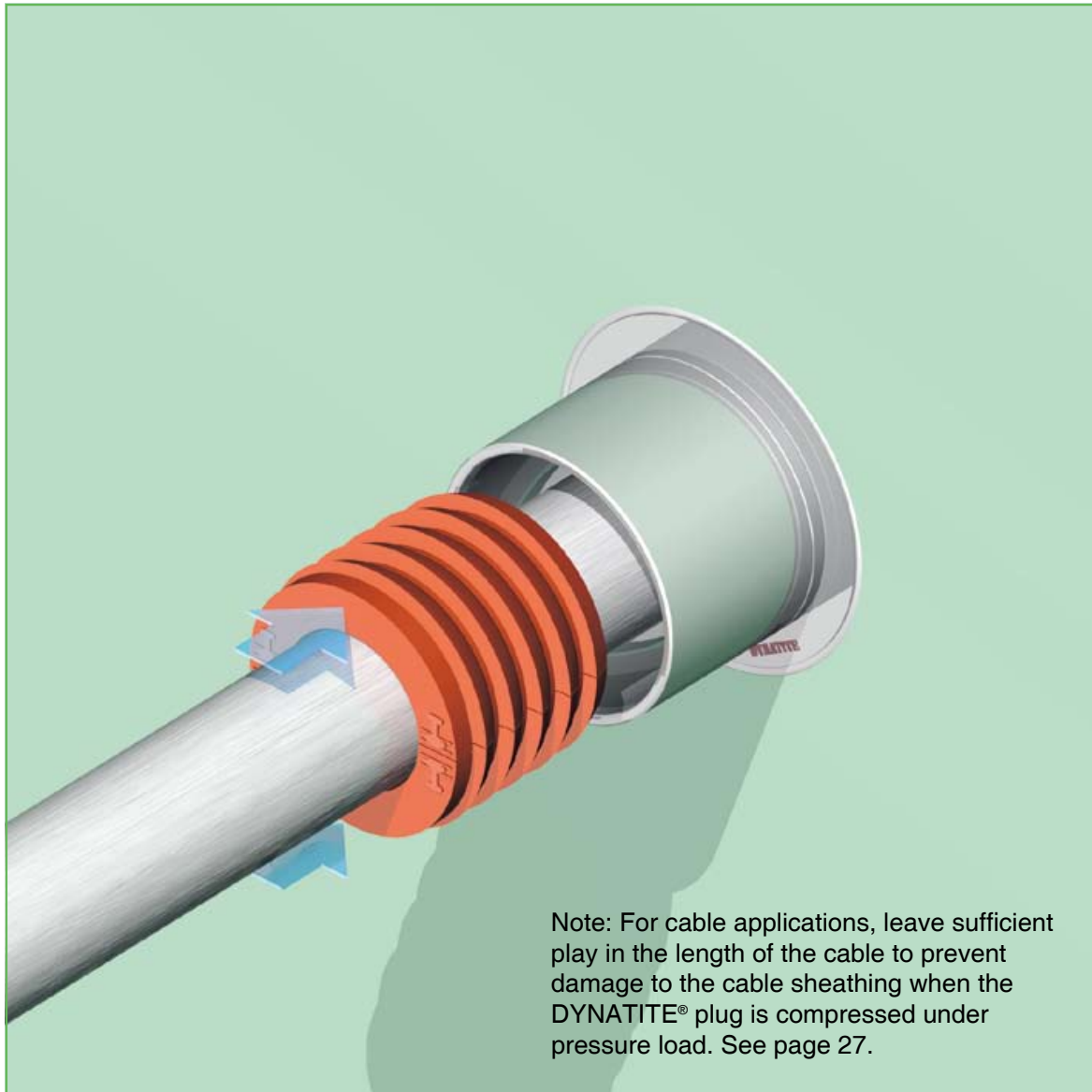

Note: For cable applications, leave sufficient play in the length of the cable to prevent damage to the cable sheathing when the DYNATITE® plug is compressed under pressure load. See page 27.

5) Both segments of the DYNATITE® sealing plug are placed around the ducted pipe/cable, then pushed into the conduit sleeve as far as the first serration. The first serration is smaller than the other serrations to make this procedure very easy. Both halves are then pushed by hand evenly, further into the DYNATITE® conduit sleeve. The inlet of the DYNATITE® conduit sleeve is rounded off to avoid any damages to the plug during insertion.



GENERAL
Marine
SERVICES

156 Beaumont Street · Westhaven · Auckland · New Zealand
Sales Ph +64 9 309 0048 · sales@generalmarine.co.nz
Service Ph +64 9 368 0938 · service@generalmarine.co.nz

www.generalmarine.co.nz



DYNATITE

**DYNATITE® DYNAMIC SEALING SYSTEM
FOR PIPE/CABLE ENTRIES**

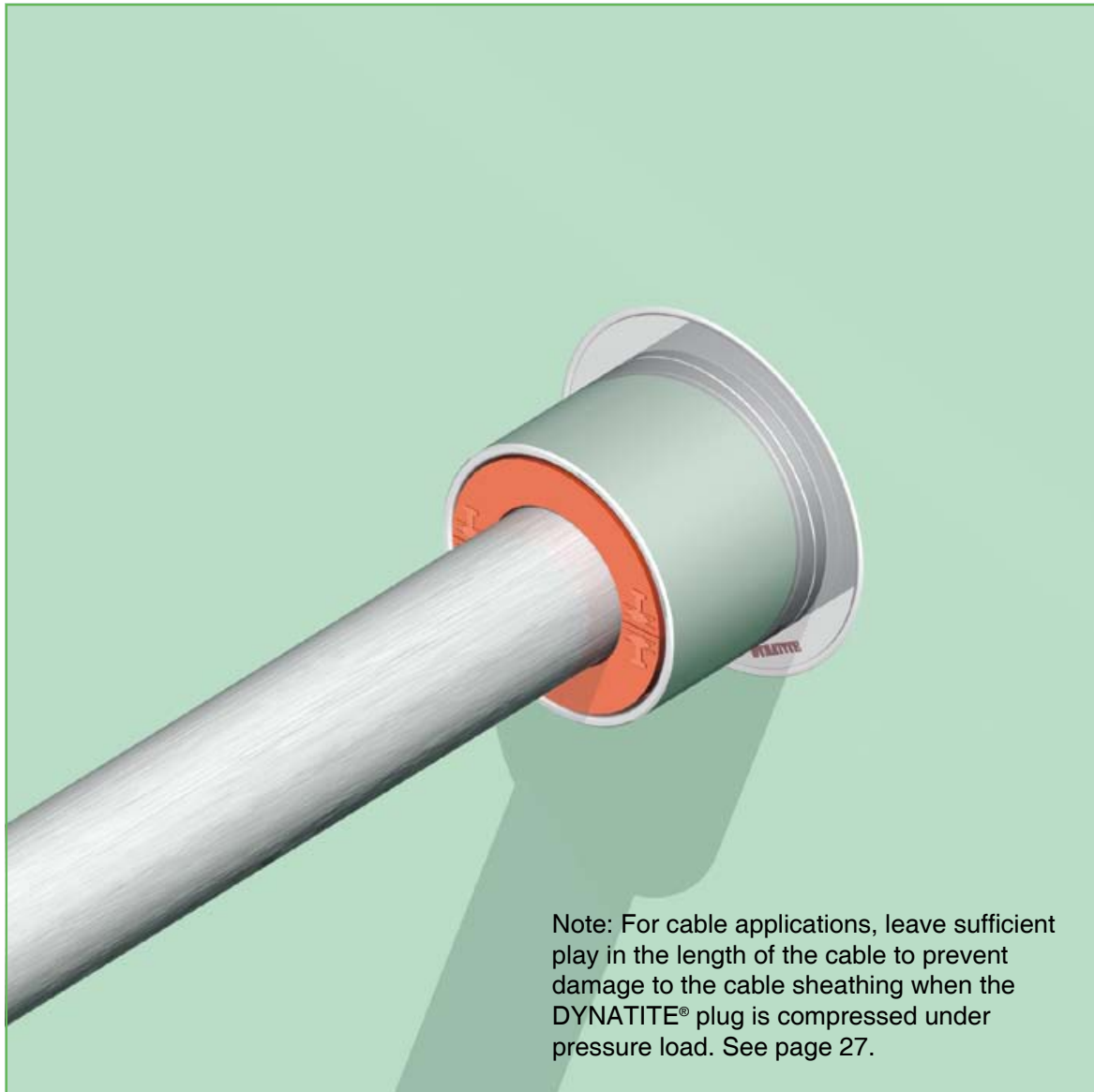

Note: For cable applications, leave sufficient play in the length of the cable to prevent damage to the cable sheathing when the DYNATITE® plug is compressed under pressure load. See page 27.

6) The front side of the DYNATITE® sealing plug must be flush with the front side of the DYNATITE® conduit sleeve. This proves that the back side of the plug is positioned against the retainer flange of the conduit sleeve. For horizontal ducts of heavy pipes/cables, it is extremely important to support the pipe/cable properly at both sides of the conduit. The DYNATITE® sealing system is a safety device. For inspection purposes, the allowed dimensions of the ducted pipe/cable are indicated on the flange of the plug.



GENERAL
Marine
SERVICES

156 Beaumont Street · Westhaven · Auckland · New Zealand
Sales Ph +64 9 309 0048 · sales@generalmarine.co.nz
Service Ph +64 9 368 0938 · service@generalmarine.co.nz

www.generalmarine.co.nz

DYNATITE

WE CARE



**DYNATITE® DYNAMIC SEALING SYSTEM
FOR PIPE/CABLE ENTRIES**

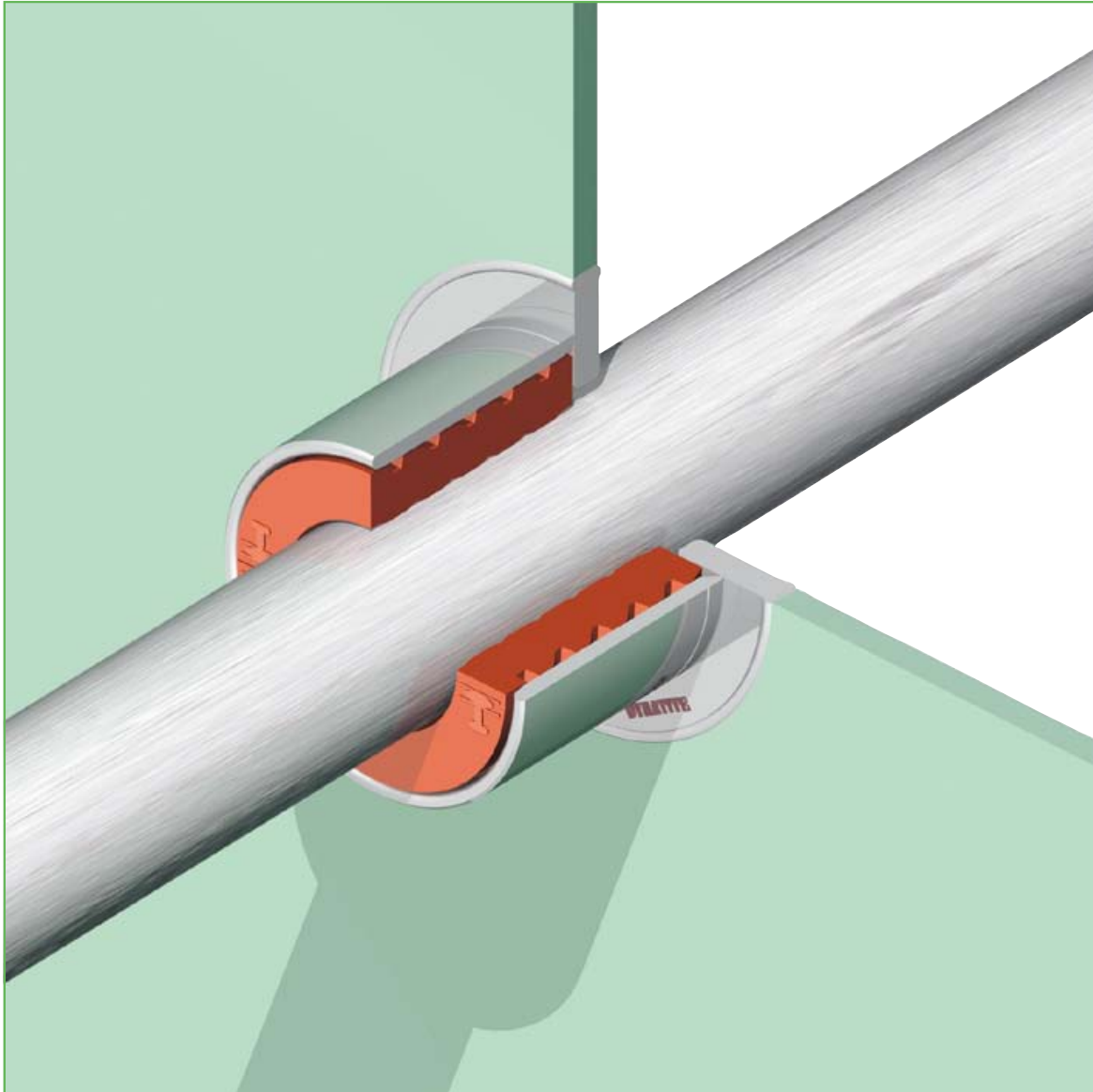

7) The DYNATITE® system has to be installed with its face on the side of the boundary that will be exposed to pressure. Otherwise the activation of the compression of the plug under pressure load is not feasible. For pressure loads from both sides, DYNATITE® conduit sleeves must be applied at both sides of the partition. The opening in the retainer flange has been dimensioned such that the use of plugs with a very thin wall thickness is prevented and also to have sufficient backing to hold the plug in place. All corners are rounded off to avoid any damage.



GENERAL
Marine
SERVICES

156 Beaumont Street · Westhaven · Auckland · New Zealand
Sales Ph +64 9 309 0048 · sales@generalmarine.co.nz
Service Ph +64 9 368 0938 · service@generalmarine.co.nz

www.generalmarine.co.nz



DYNATITE

**DYNATITE® DYNAMIC SEALING SYSTEM
FOR PIPE/CABLE ENTRIES**

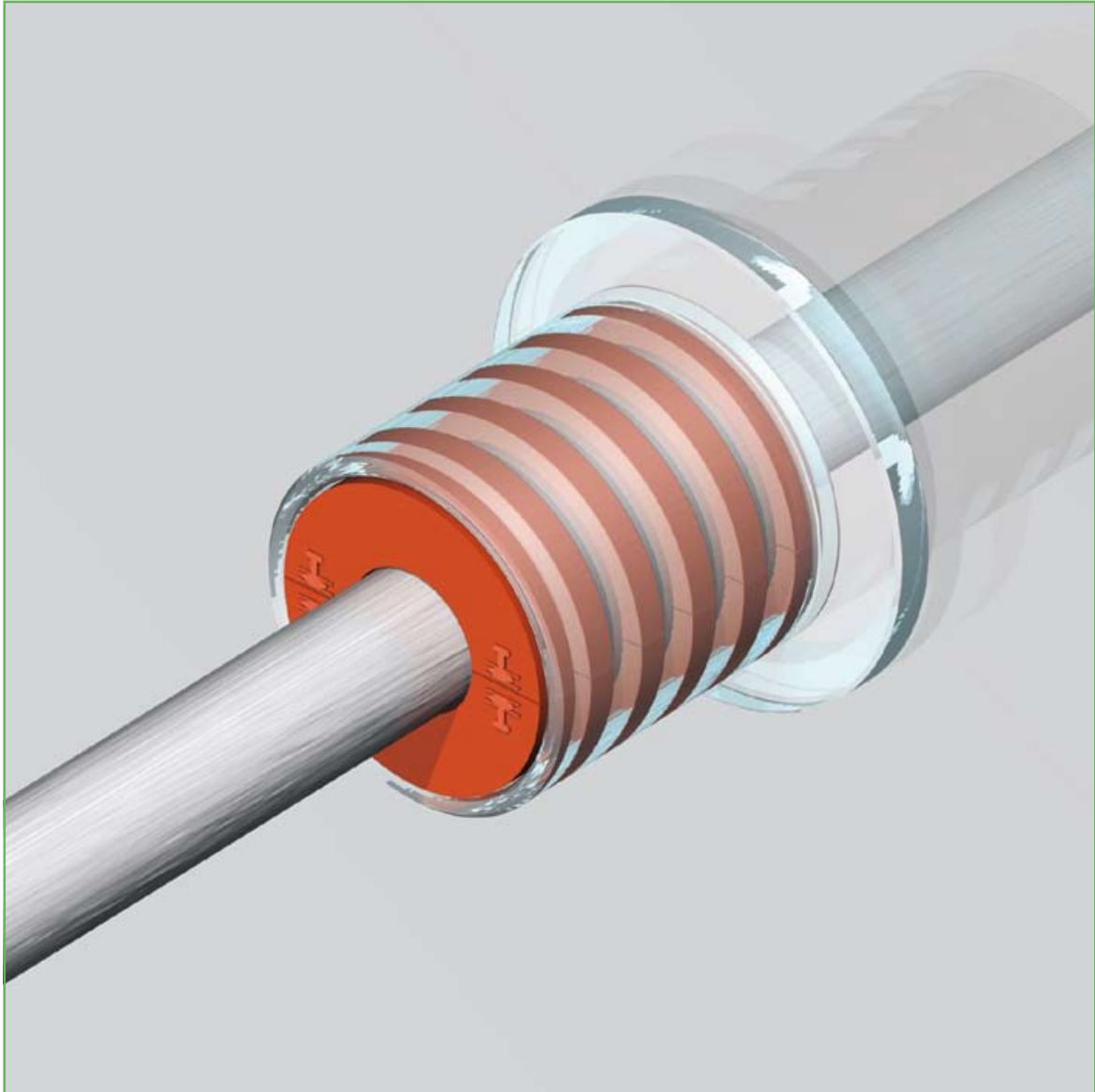

The basics of the DYNATITE® technology visualized.

During insertion of the DYNATITE® plug, a labyrinth seal is formed against the wall of the conduit sleeve by the serrated and leveled other profiling of the plug. This is also the case on the contact surfaces with the ducted pipe/cable. As has been proven with the SLIPSIL® plugs having the same profiling, pressure loads of up to 2.5 bar can be easily withstood. DYNATITE® is designed for higher pressures, which means that the profiling has to get dynamically activated under pressure load.



GENERAL
Marine
SERVICES

156 Beaumont Street · Westhaven · Auckland · New Zealand
Sales Ph +64 9 309 0048 · sales@generalmarine.co.nz
Service Ph +64 9 368 0938 · service@generalmarine.co.nz

www.generalmarine.co.nz

DYNATITE

WE CARE



**DYNATITE® DYNAMIC SEALING SYSTEM
FOR PIPE/CABLE ENTRIES**

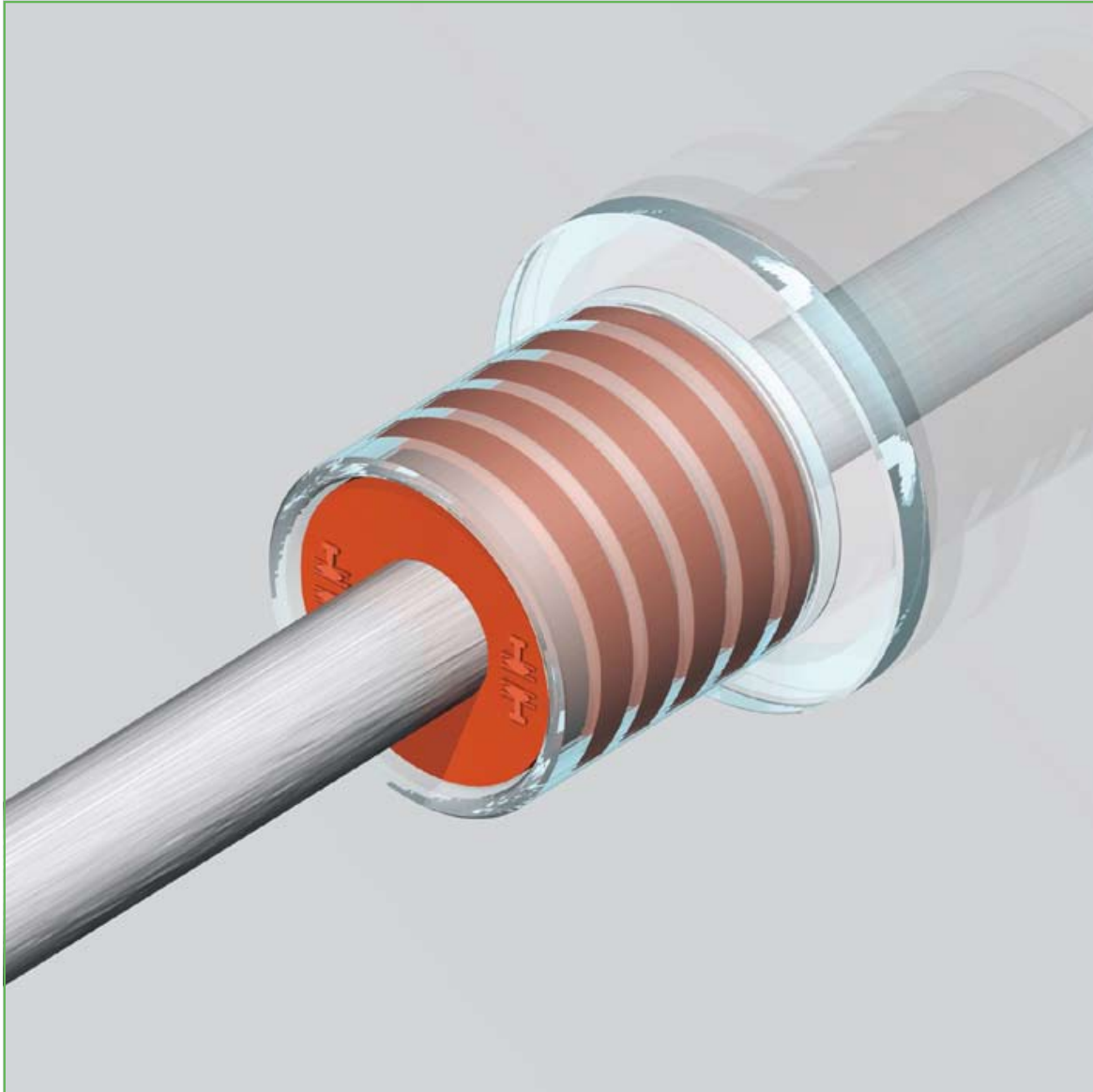

The basics of the DYNATITE® technology visualized.
The DYNATITE® and SLIPSIL® plugs are based on an engineered design with regard to the profiling, dimensions and hardness and flexibility of the rubber grade. The result is that the plug can be compressed. By enclosing the plug inside the DYNATITE® conduit sleeve with the retainer flange, compression is feasible. The pressure load will force the plug further into the conduit sleeve, and the rings of the created labyrinth seal are getting thicker and in this way tightness ratings are increasing.



GENERAL
Marine
SERVICES

156 Beaumont Street · Westhaven · Auckland · New Zealand
Sales Ph +64 9 309 0048 · sales@generalmarine.co.nz
Service Ph +64 9 368 0938 · service@generalmarine.co.nz

www.generalmarine.co.nz



DYNATITE® DYNAMIC SEALING SYSTEM FOR PIPE/CABLE ENTRIES

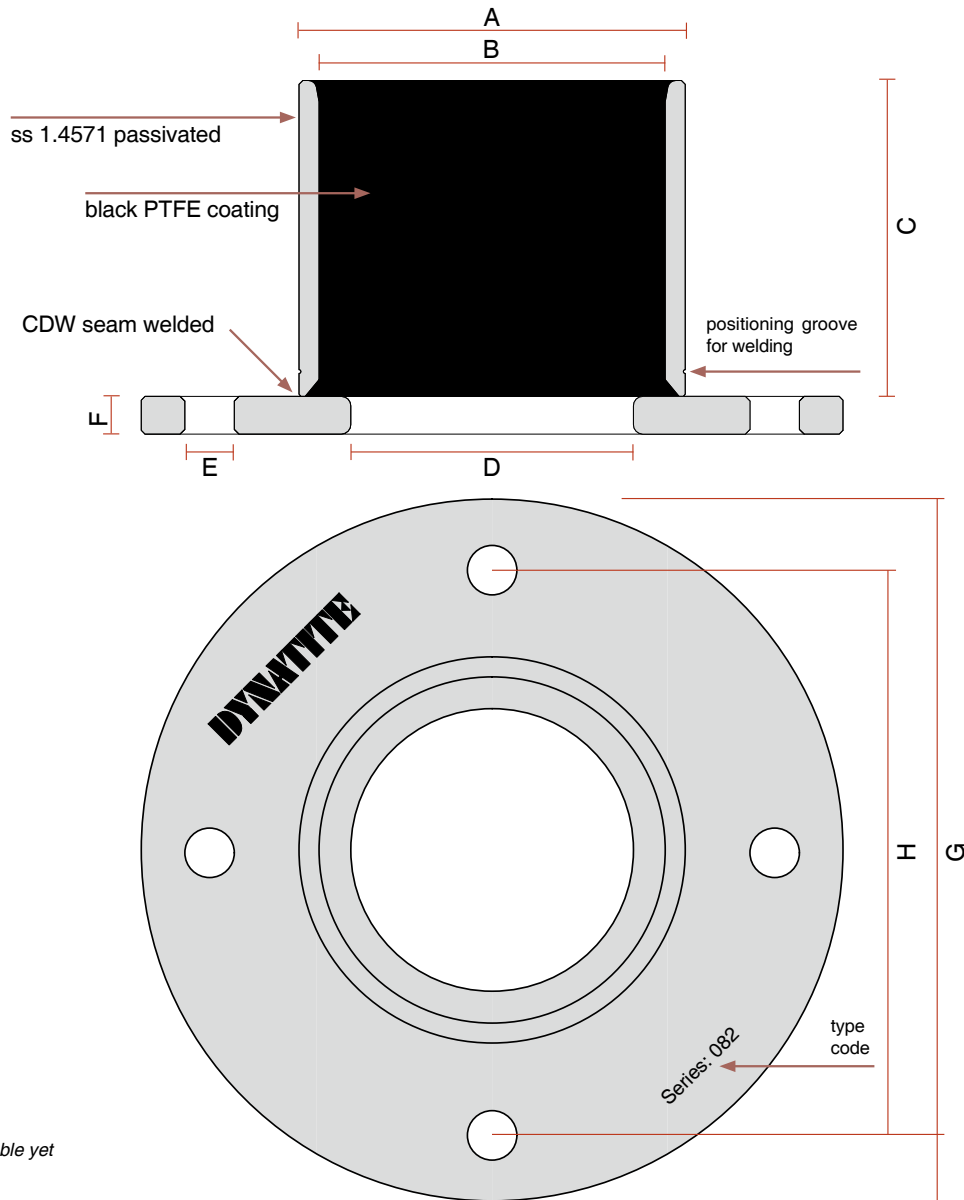

* not available yet

All dimensions in mm

type	A	B	C	D	E	F	G	H	art. no.	gasket	art. no.
DT 25 FB	33.5	25	54	12	10.5	8	92	63	60.9000	DT 25 FB	51.9000
DT 32 FB	40.5	32	54	16	10.5	8	99	70	60.9001	DT 32 FB	51.9001
DT 41 FB	49.5	41	54	25	10.5	8	108	79	60.9002	DT 41 FB	51.9002
DT 55 FB	63.5	55	66	34	10.5	8	122	93	60.9003	DT 55 FB	51.9003
DT 70 FB*	78.5	70	66	50	10.5	8	137	108	60.9004	DT 70 FB	51.9004
DT 82 FB	90.5	82	66	60	10.5	8	149	120	60.9005	DT 82 FB	51.9005
DT 100 FB*	108.5	100	66	75	10.5	8	167	138	60.9006	DT 100 FB	51.9006
DT 125 FB*	133.5	125	66	95	10.5	8	192	163	60.9007	DT 125 FB	51.9007
DT 150 FB*	158.5	150	79	120	10.5	8	217	188	60.9008	DT 150 FB	51.9008



GENERAL
Marine
SERVICES

156 Beaumont Street · Westhaven · Auckland · New Zealand

Sales Ph +64 9 309 0048 · sales@generalmarine.co.nz

Service Ph +64 9 368 0938 · service@generalmarine.co.nz

www.generalmarine.co.nz

DYNATITE

WE CARE



**DYNATITE® DYNAMIC SEALING SYSTEM
FOR PIPE/CABLE ENTRIES**

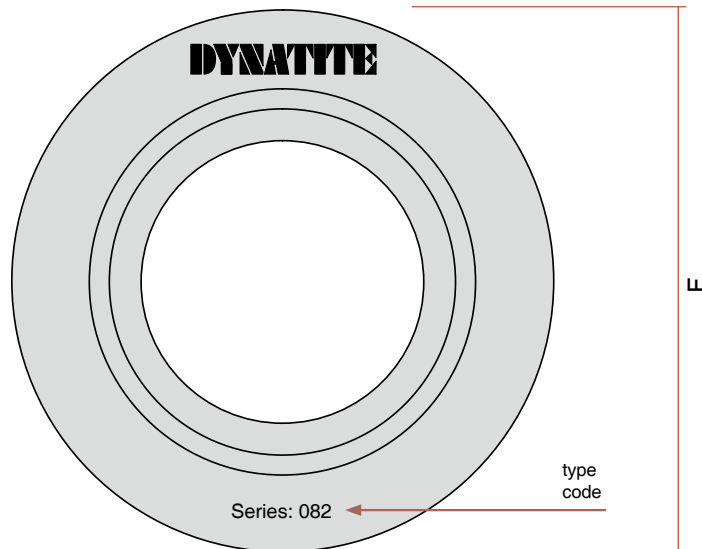
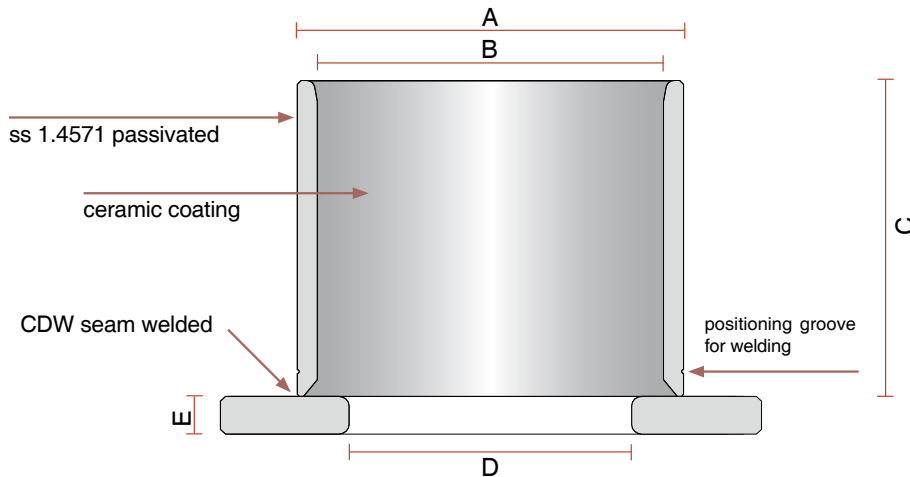

* not available yet

All dimensions in mm

type	A	B	C	D	E	F	art. no.
DT 25 FW	33.5	25	54	12	8	58	60.9020
DT 32 FW	40.5	32	54	16	8	65	60.9021
DT 41 FW	49.5	41	54	25	8	74	60.9022
DT 55 FW	63.5	55	66	34	8	88	60.9023
DT 70 FW*	78.5	70	66	50	8	103	60.9024
DT 82 FW	90.5	82	66	60	8	115	60.9025
DT 100 FW*	108.5	100	66	75	8	133	60.9026
DT 125 FW*	133.5	125	66	95	8	158	60.9027
DT 150 FW*	158.5	150	79	120	8	183	60.9028



GENERAL
Marine
SERVICES

156 Beaumont Street · Westhaven · Auckland · New Zealand

Sales Ph +64 9 309 0048 · sales@generalmarine.co.nz

Service Ph +64 9 368 0938 · service@generalmarine.co.nz

www.generalmarine.co.nz



DYNATITE® DYNAMIC SEALING SYSTEM FOR PIPE/CABLE ENTRIES

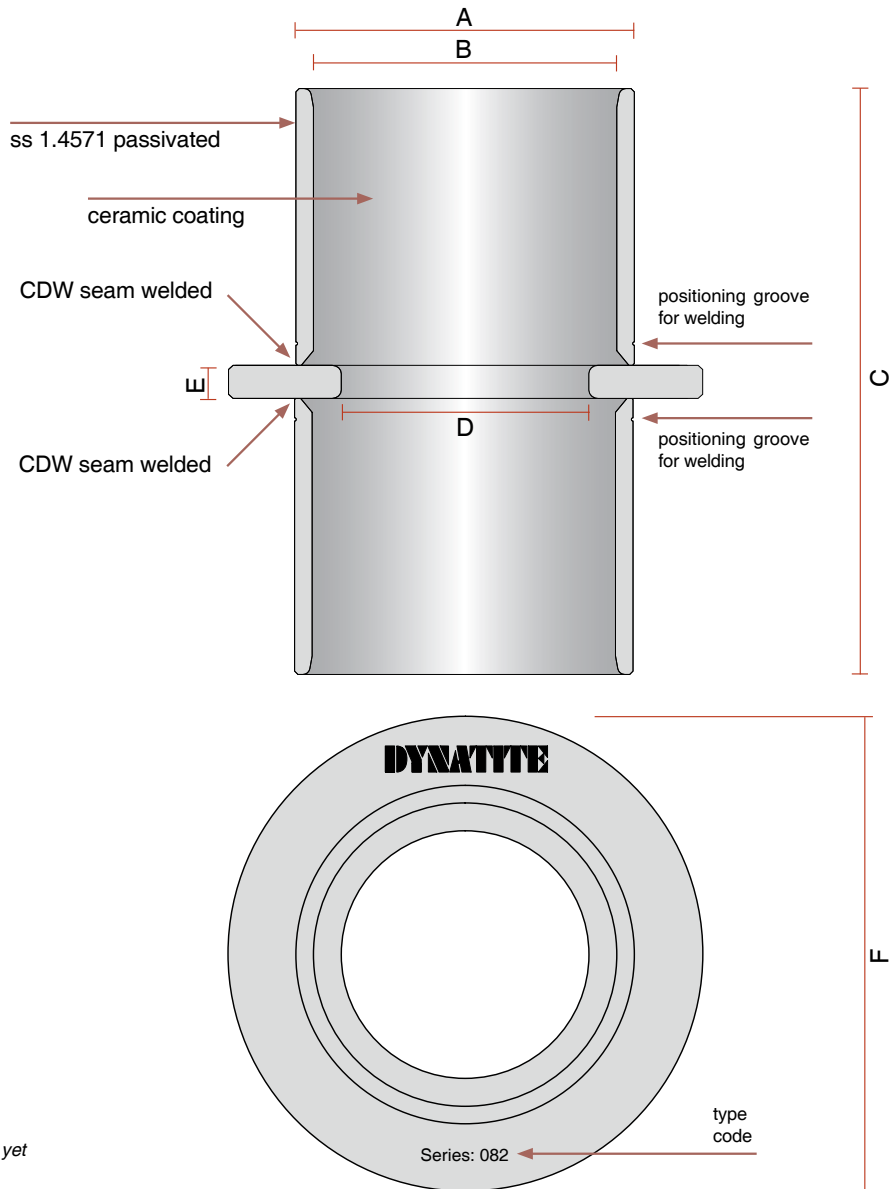

* not available yet

All dimensions in mm

type	A	B	C	D	E	F	art. no.
DT 25 FWD*	33.5	25	116	12	8	58	60.9040
DT 32 FWD*	40.5	32	116	16	8	65	60.9041
DT 41 FWD*	49.5	41	116	25	8	74	60.9042
DT 55 FWD*	63.5	55	140	34	8	88	60.9043
DT 70 FWD*	78.5	70	140	50	8	103	60.9044
DT 82 FWD*	90.5	82	140	60	8	115	60.9045
DT 100 FWD*	108.5	100	140	75	8	133	60.9046
DT 125 FWD*	133.5	125	140	95	8	158	60.9047
DT 150 FWD*	158.5	150	166	120	8	183	60.9048



GENERAL
Marine
SERVICES

156 Beaumont Street · Westhaven · Auckland · New Zealand



Sales Ph +64 9 309 0048 · sales@generalmarine.co.nz

Service Ph +64 9 368 0938 · service@generalmarine.co.nz

www.generalmarine.co.nz



DYNATITE® DYNAMIC SEALING SYSTEM FOR PIPE/CABLE ENTRIES

	cable/ pipe diameter	plug type	article number	cable/ pipe diameter	plug type	article number	
 <p>type code: series/cable-pipe diameter For instance 55/22-24DT</p>	5-6	25/5-6DT	45.0105	28-30	82/28-30DT	45.2418	
	6-7	25/6-7DT	45.0106	30-32	82/30-32DT	45.2419	
	7-8	25/7-8DT	45.0107	32-34	82/32-34DT	45.2420	
	8-9	25/8-9DT	45.0108	34-36	82/34-36DT	45.2421	
	 <p>type code: series/2xcable diameter For instance 55/2x12-14DT</p>	5-6	32/5-6DT	45.0505	36-38	82/36-38DT	45.2422
		6-7	32/6-7DT	45.0506	38-40	82/38-40DT	45.2423
		7-8	32/7-8DT	45.0507	40-42	82/40-42DT	45.2424
		8-9	32/8-9DT	45.0508	42-44	82/42-44DT	45.2425
		9-10	32/9-10DT	45.0509	44-46	82/44-46DT	45.2426
		10-11	32/10-11DT	45.0510	46-48	82/46-48DT	45.2427
		11-12	32/11-12DT	45.0511	48-50	82/48-50DT	45.2428
		12-13	32/12-13DT	45.0512	50-52	82/50-52DT	45.2429
 <p>type code: series/3xcable diameter For instance 55/3x8-9DT</p>		12-13	41/5-6DT	45.1005	12-13	82/2x12-13DT	45.2441
		6-7	41/6-7DT	45.1006	13-14	82/2x13-14DT	45.2442
		7-8	41/7-8DT	45.1007	14-15	82/2x14-15DT	45.2443
		8-9	41/8-9DT	45.1008	15-16	82/2x15-16DT	45.2444
	9-10	41/9-10DT	45.1009	16-17	82/2x16-17DT	45.2445	
	10-11	41/10-11DT	45.1010	17-18	82/2x17-18DT	45.2446	
	11-12	41/11-12DT	45.1011	18-19	82/2x18-19DT	45.2447	
	12-14	41/12-14DT	45.1012	19-20	82/2x19-20DT	45.2448	
	14-16	41/14-16DT	45.1013	20-21	82/2x20-21DT	45.2449	
	16-18	41/16-18DT	45.1014	10-11	82/3x10-11DT	45.2456	
	18-20	41/18-20DT	45.1015	11-12	82/3x11-12DT	45.2457	
	6-7	41/2x6-7DT	45.1026	12-13	82/3x12-13DT	45.2458	
7-8	41/2x7-8DT	45.1027					
8-9	41/2x8-9DT	45.1028					
14-16	55/14-16DT	45.1411					
16-18	55/16-18DT	45.1412					
18-20	55/18-20DT	45.1413					
20-22	55/20-22DT	45.1414					
22-24	55/22-24DT	45.1415					
24-26	55/24-26DT	45.1416					
26-28	55/26-28DT	45.1417					
28-30	55/28-30DT	45.1418					
6-7	55/2x6-7DT	45.1431					
7-8	55/2x7-8DT	45.1432					
8-9	55/2x8-9DT	45.1433					
9-10	55/2x9-10DT	45.1434					
10-11	55/2x10-11DT	45.1435					
11-12	55/2x11-12DT	45.1436					
12-13	55/2x12-13DT	45.1437					
6-7	55/3x6-7DT	45.1441					
7-8	55/3x7-8DT	45.1442					
8-9	55/3x8-9DT	45.1443					





DYNATITE

**DYNATITE® DYNAMIC SEALING SYSTEM
FOR PIPE/CABLE ENTRIES**

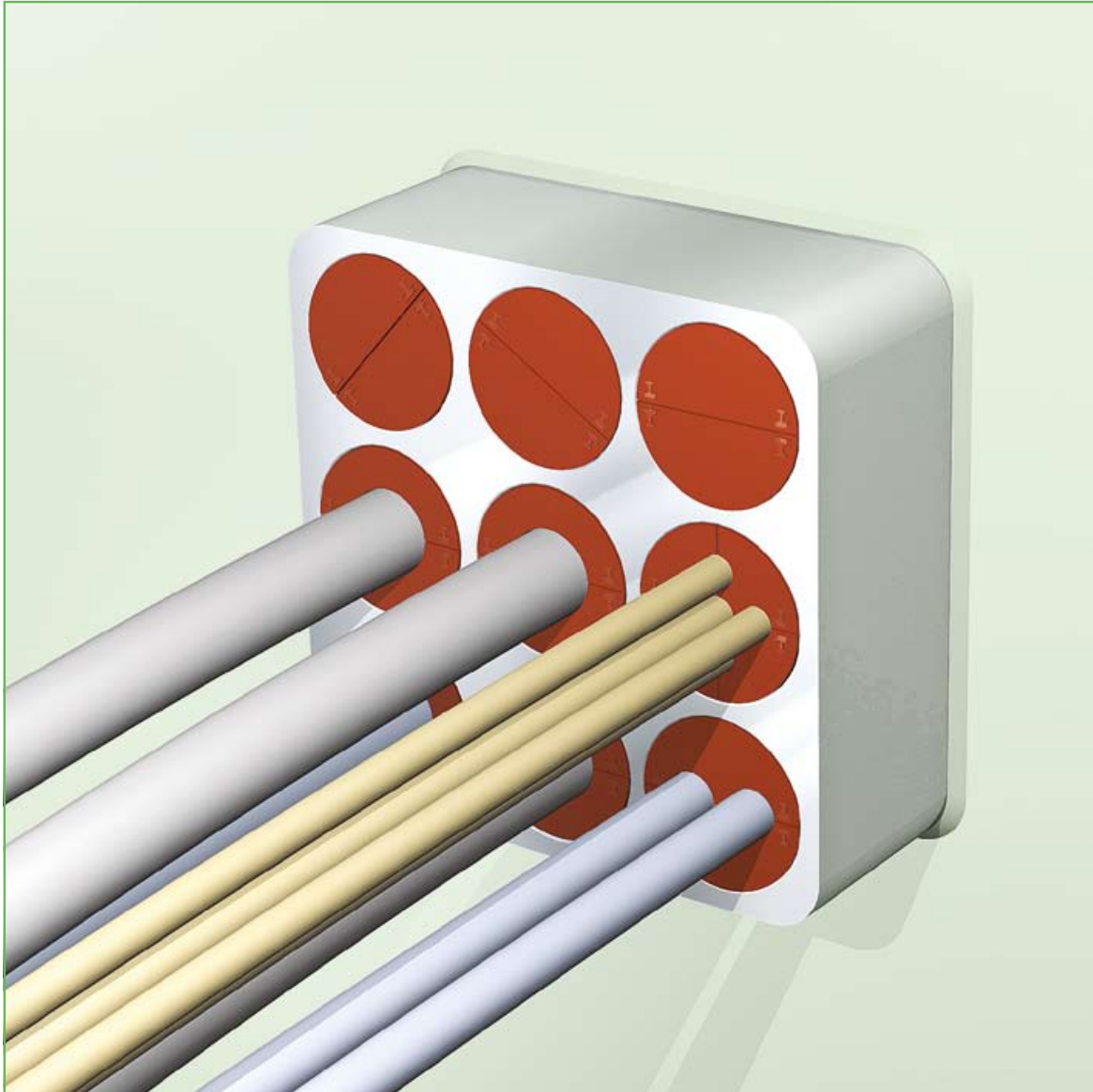

DYNATITE® multi-passage units which are manufactured with exact fitting dimensions to adopt the sealing plugs and to allow the required movement of the rubber. In this simple way, pressures in excess of 10 bar can easily be coped with. The DYNATITE® dynamic sealing system holds also static tight after dynamic exposure. The DYNATITE® multi-passage units will be supplied in various configurations. Due to required weight savings in constructions these days, our R&D department is evaluating several options to manufacture the units.



GENERAL
Marine
SERVICES

156 Beaumont Street · Westhaven · Auckland · New Zealand
Sales Ph +64 9 309 0048 · sales@generalmarine.co.nz
Service Ph +64 9 368 0938 · service@generalmarine.co.nz

www.generalmarine.co.nz



WE CARE



BEELE - RESEARCH & DEVELOPMENT PRODUCTS FOR SPECIAL APPLICATIONS

NOFIRNO® *NEW TECHNOLOGY*

- Approved for harshest fire ratings for pipe penetrations (A, H and Jet Fire class).
- Allows substantial movement of the ducted pipe within the conduit.
- High pressure ratings - designed for gas and/or watertight penetrations.
- Prevents corrosion inside the penetration.
- Longest service life and best Total Cost of Ownership on the market.
- NOFIRNO® rubber sleeves and sealant will remain stable and not be consumed by fire.
- **Breakthrough - MULTI-ALL-MIX SYSTEM®**
- Approved for any combination of cable and/or metallic, GRP or plastic pipes!



NOFIRNO® *NEW TECHNOLOGY*

- Gaskets and rubber sheets for applications in which the transits, coamings or conduit sleeves are bolted to the partition.
- Successfully tested for A-class RISE®, RIACNOF® and NOFIRNO® sealing systems for multi-cable and pipe transits bolted to the partitions.
- NOFIRNO® rubber will remain stable and not be consumed by fire.
- NOFIRNO® rubber has excellent resistance against UV, Ozone and weathering.
- Wide temperature range: -50 °C up to +180 °C.
- **Proven - harshest fire exposure**
- Special sizes of gaskets upon request.
- Products made of NOFIRNO® rubber upon request.



ACTIFOAM® /ULTRA *NEWEST TECHNOLOGY*

- Sealing of gaps and openings in constructions against the ingress of moisture and to avoid flame spread.
- ACTIFOAM® has high thermal insulation values due to the closed cellular structure.
- RISE®/ULTRA - adhesive properties under fire load.
- **Breakthrough - ACTIFOAM® sheets can be layered with RISE/ULTRA sheets.**
- The sandwich construction acts as a “bridge bearing” enabling the carrying of very high loads.
- Highest fire ratings achievable due to the unique combination of the two rubber grades.
- Successfully subjected to two hour hydrocarbon fire.

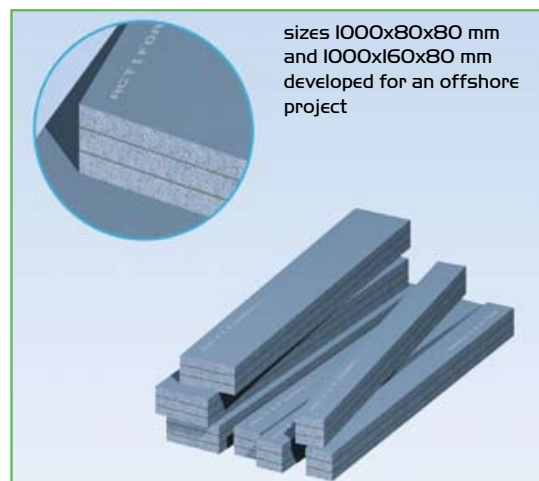

GENERAL
Marine
SERVICES

156 Beaumont Street · Westhaven · Auckland · New Zealand
Sales Ph +64 9 309 0048 · sales@generalmarine.co.nz
Service Ph +64 9 368 0938 · service@generalmarine.co.nz

www.generalmarine.co.nz

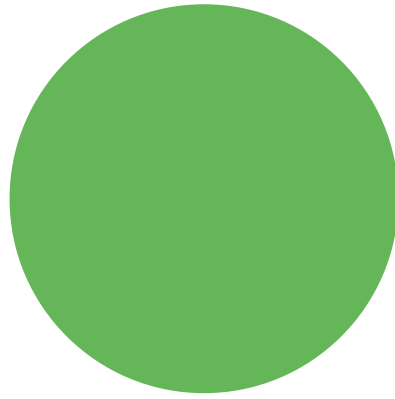

WE CARE

**BEELE ENGINEERING:
A COMPANY DEDICATED TO SAFETY
FOR OVER 35 YEARS**



BEELE Engineering bv - CSD International bv
Beunkdijk 11 - 7122 NZ AALTEN - THE NETHERLANDS
Tel. +31 543 461629 - Fax +31 543 461786 - E-mail: info@beele.com
**Websites: <http://www.beele.com> (and/or www.actifoam.com, www.firsto.com, www.nofirno.com,
www.rise-systems.com, www.rise-nofirno.com, www.riswat.com and www.slipsil.com)**



GENERAL
Marine
SERVICES

156 Beaumont Street · Westhaven · Auckland · New Zealand
Sales Ph +64 9 309 0048 · sales@generalmarine.co.nz
Service Ph +64 9 368 0938 · service@generalmarine.co.nz

www.generalmarine.co.nz