

1281

Filtro depurazione acqua con flange PN6/PN16
Horizontal intake water strainer with PN6/PN16 flanges

Filtro omologato RINA MAC
RINA MAC certificate



Tabella flange a pag. 182
Flange table on page 182

* Con flangia PN16
With flange PN16

	1281	14500	21000	26000	39000	50000	80000	138500
Weight (gr)*	10900	14500	21000	26000	39000	50000	80000	138500
	3281	4950	7150	8840	13260	17000	27200	47100
Weight (gr)*	3750	4950	7150	8840	13260	17000	27200	47100
d	8.5	8.5	8.5	8.5	8.5	8.5	10.5	10.5
A	108	122	142	166	188	214	260	320
B	108	122	132	150	170	210	240	280
H	225	273	302	350	430	468	575	685
H1	147	184.5	205	243	306	325.5	400	485
L1	102	117	130	150	170	190	215	255
L	225	260	290	338	380	425	500	600
DN	50	65	80	100	125	150	200	250

Bronzo
Bronze

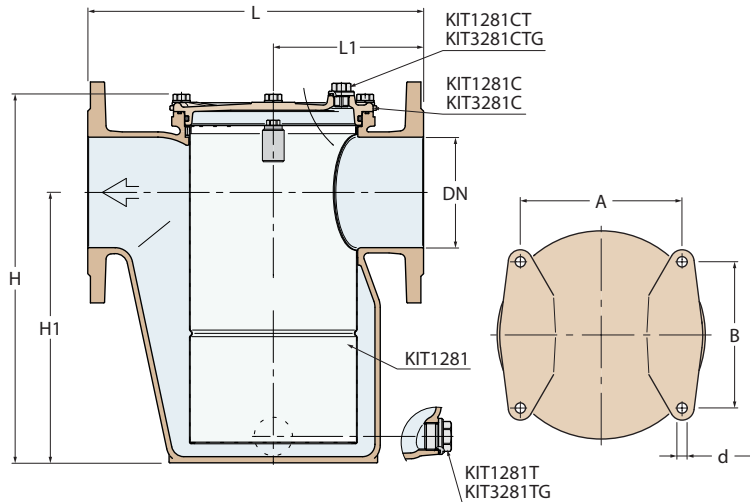
3281



Alluminio anodizzato nero
Black anodized aluminium

Diagramma portate - perdite di carico
Flow rate - loss of pressure diagram

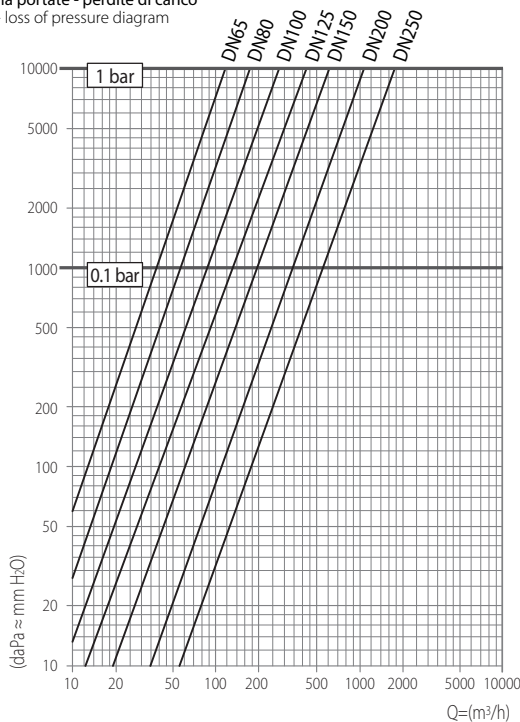

Corpo in bronzo / Alluminio anodizzato nero
Bronze / Black anodized aluminium casing

Elemento filtrante in acciaio inox AISI 316L
AISI 316L stainless steel inside filter

Coperchio in bronzo / Alluminio anodizzato nero
Bronze / Black anodized aluminium cover

Guarnizioni in neoprene
Neoprene o-ring

DN	0.1 bar	1 bar
65	37000	117000
80	56100	177200
100	88000	277000
125	136800	432700
150	197000	623000
200	350000	1108000
250	564500	1786000

Portate di acqua attraverso il filtro pulito - lt/h
Flow-rate capacity through the clean filter - lt/h