

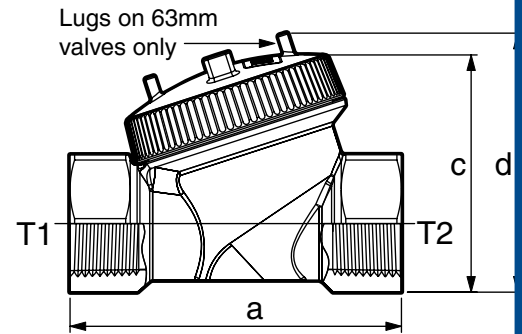

Email: [info@hansenproducts.com](mailto:info@hansenproducts.com)  
 Website: [www.hansenproducts.com](http://www.hansenproducts.com)

## Hansen Check Valve Dimensions

Product Code	T1 BSPT (DN*)	T2 BSPT (DN*)	a mm	b mm	c mm	d mm
CV25	25mm (1")	25mm (1")	102	69	74	NA
CV32	32mm (1 1/4")	32mm (1 1/4")	122	87	94	NA
CV40	40mm (1 1/2")	40mm (1 1/2")	133	99	106	NA
CV50	50mm (2")	50mm (2")	164	123	132	NA
CV63	63mm (2 1/2")	63mm (2 1/2")	198	152	NA	180



## Hansen Check Valve Flow Chart

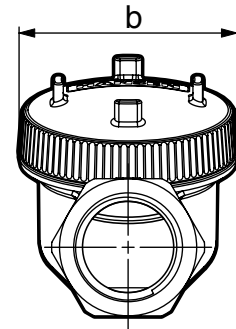
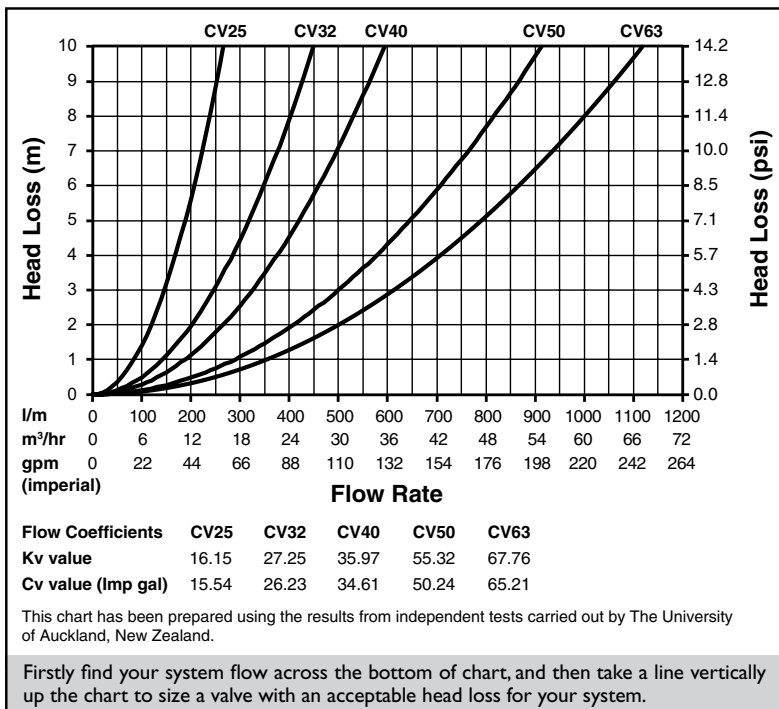

## Standards & Approvals



Class SGS  
 Marine  
 Certificate

For further technical information, including chemical & temperature specifications, please visit our website: [www.hansenproducts.com](http://www.hansenproducts.com)



GENERAL  
 Marine  
 SERVICES

156 Beaumont Street · Westhaven · Auckland · New Zealand  
 Sales Ph +64 9 309 0048 · [sales@generalmarine.co.nz](mailto:sales@generalmarine.co.nz)  
 Service Ph +64 9 368 0938 · [service@generalmarine.co.nz](mailto:service@generalmarine.co.nz)

[www.generalmarine.co.nz](http://www.generalmarine.co.nz)