

## T-Piece Connector / Universal Manifold

A versatile building-block, the **TRUDESIGN**® T-Piece Connector functions not only as a T-Piece but also as an expandable manifold. The **TRUDESIGN**® T-Piece Connector features two 1½" female parallel threads and one 1½" male parallel thread allowing manifolds to be created simply by joining two or more parts together. This allows users to channel multiple drains to one Ball Valve–Skin Fitting thru-hull outlet, eliminating the need for additional thru-hull fittings.

The flexibility of the **TRUDESIGN**® T-Piece Connector allows:

- Mixed sizes of hose tail fittings to select from to suit ¾", 1", 1¼" & 1½" I.D hose
- Neat and tidy routing of hoses with a range of hose tail directions available including straight, 90°, & 120°
- Direct connection to a 1½" Ball Valve or 1½" (above waterline) Skin Fitting
- Connection to plumbing pipework or a secondary Ball Valve with use of the Threaded Connector



The **TRUDESIGN**® T-Piece Connector is commonly used in glycol/antifreeze flush-through systems when preparing for winterization, or, in fresh water engine flush systems. By adding a plug to the female end, the T-Piece Connector can function as an inspection port for looking through to, or clearing the internals of a Ball Valve.

### Key Features:

Feature:	
User selectable hose tails	Varying sizes of hose (from ¾" to 1½") can connect to one T-Piece
Expandable	Create multi-port manifolds easily by joining two or more T-Pieces
Ability to secure to a wall or bulkhead*	By attaching the <b>TRUDESIGN</b> ® T-Piece Wall Bracket <span style="float: right;">*available late 2016</span>
Manufactured from a glass-reinforced nylon composite	High strength and light weight
Immune to corrosion and electrolysis	Long- life with no concerns over decreased performance due to corrosion
Chemical resistant	Unaffected by diesel, petrol and chemicals
BSPF (Parallel) threads	Universal compatibility to <b>TRUDESIGN</b> ® Ball Valves, threaded fittings, and other marine components. Allows 0 - 360° orientations with mating parts.
Large operating temperature range	Suitable for all marine environments, from -20°C to +100°C

Page 1 of 4



**Versatility:**

Compatible with the following TRUDESIGN® fittings;

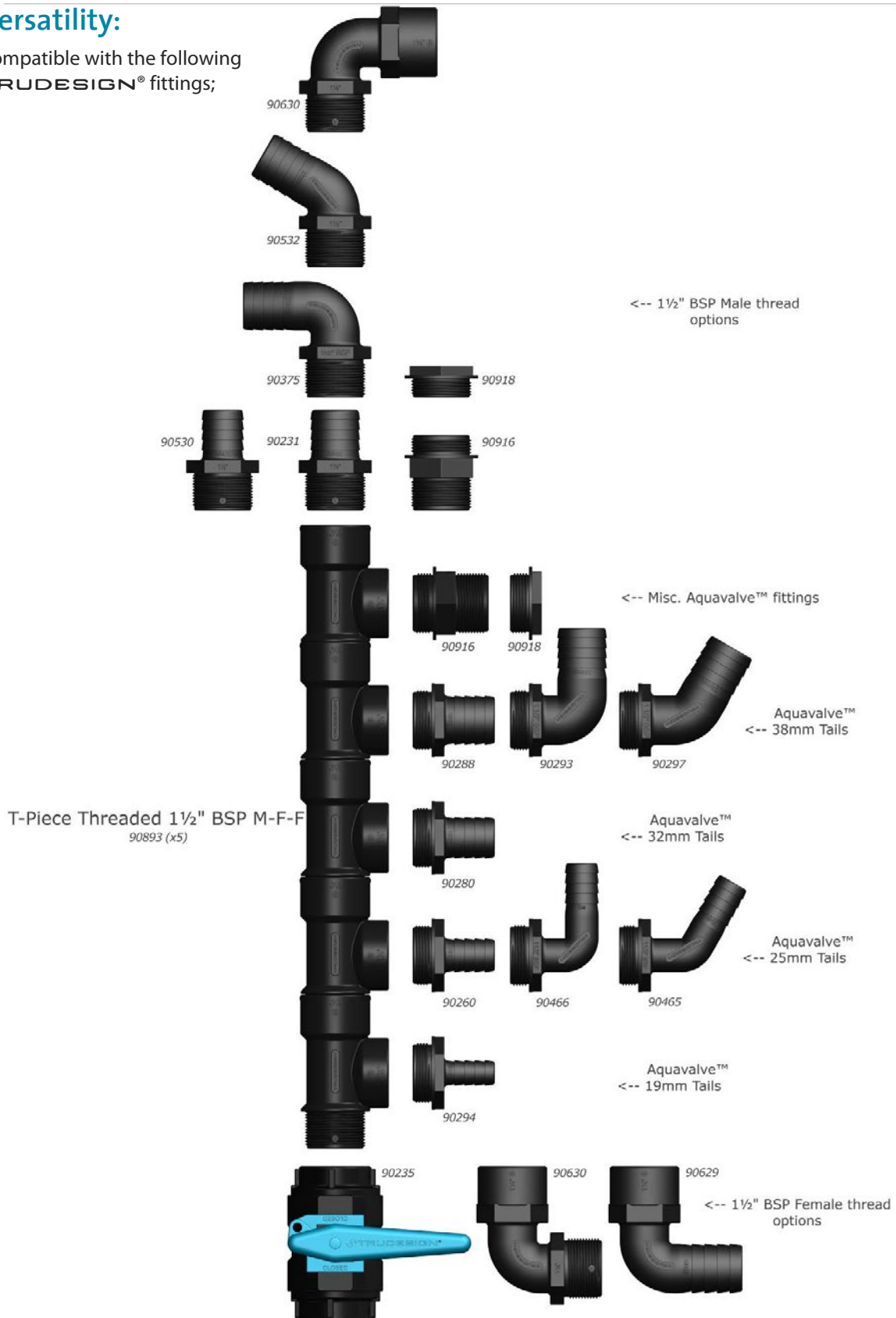

## Compatible Part Numbers (shown previous page):

Model / Size	Part Number	Part Number PKG
<b>T-Piece Connector 1½" BSP M-F-F</b>	<b>90893</b>	<b>90894</b>
Aquavalve Tail 38mm (1½") 1½" BSP Black	<b>90288</b>	<b>90545</b>
Aquavalve Tail 32mm (1¼") 1½" BSP Black	<b>90280</b>	<b>90544</b>
Aquavalve Tail 25mm (1") 1½" BSP Black	<b>90260</b>	<b>90543</b>
Aquavalve Tail 19mm (¾") 1½" BSP Black	<b>90249</b>	<b>90542</b>
Aquavalve 90° 38mm (1½") 1½" BSP Black		<b>90293</b>
Aquavalve 90° 25mm (1") 1½" BSP Black		<b>90466</b>
Aquavalve 120° 38mm (1½") 1½" BSP Black		<b>90297</b>
Aquavalve 120° 25mm (1") 1½" BSP Black		<b>90465</b>
Tail 38mm (1½") 1½" BSP Long Thread	<b>90231</b>	<b>90561</b>
Tail 32mm (1¼") 1½" BSP Long Thread	<b>90284</b>	<b>90563</b>
Tail 38mm (1½") 1½" BSP Long Thread 90°	<b>90375</b>	<b>90569</b>
Tail 38mm (1½") 1½" BSP Long Thread 120°	<b>90532</b>	<b>90573</b>
Tail 38mm (1½") 1½" BSP Female 90° Bend	<b>90629</b>	<b>90635</b>
Connector 1½" BSP F 1½" BSP M 90°	<b>90630</b>	<b>90636</b>
Plug 1½" BSP Black	<b>90918</b>	<b>90919</b>
Connector Threaded 1½" BSP / 1½" BSP Black	<b>90916</b>	<b>90917</b>
Ball Valve 1½" BSP	<b>90235</b>	<b>90552</b>
Ball Valve Position Monitored 1½" BSP		<b>90236</b>
Skin Fitting 1½" BSP Black		<b>90418</b>
Skin Fitting 1 ½" BSP White		<b>90419</b>
Skin Fitting Recessed 1½" BSP Black		<b>90680</b>
Skin Fitting Recessed 1½" BSP White		<b>90713</b>

Note: 'PKG' denotes packaged item supplied in bag with header card. Some items only sold as packaged.

## Specifications:

Threads on the T-Piece Connector / Universal Manifold are 1½" BSPP (British Standard Pipe Parallel).

**TRUDESIGN**® parallel threads are designed so that sealant or PTFE thread tape is applied to the male thread, and then the fitting screwed into place. A main advantage of parallel versus tapered threads is that there is far greater engagement between two mating parallel threads which in turn provides greater strength and watertight sealing ability. Since sealing is achieved through use of a sealant or thread tape, fittings can be positioned anywhere around 360°, unlike tapered fittings that need to be fully tightened in order to seal.

**Do not use with tapered thread valves or fittings** – Mixing parallel and tapered threads can cause strength and sealing problems as the thread engagement is often only a few turns.

Tapered threads should **never** be used in marine applications.



### Installation:

- 1.) Ensure all fittings that the T-Piece Connector is attaching with have clean and undamaged threads.
- 2.) Apply a small amount of a suitable marine grade thread sealant such as SIKAFLEX® 291i or 3M™ Fast Cure 5200 to the male threads, or wind several turns of PTFE thread sealing tape onto the threads (clockwise when viewed from the bottom of the thread).

*Tip – when creating manifolds or large assemblies, perform a ‘dry’ fit of parts then fit in vessel to check clearances before applying any sealants or thread tape.*

- 3.) Screw down fully, ensuring not to over-tighten. Make sure the final positions of tail fittings are clear of items such as the Ball Valve’s handle operation path and/or hoses can be fitted easily once assembled.

**Note: When a liquid type thread sealant is used, fittings do not need to be fully tightened as the sealant will provide full waterproofness once cured. This allows orientation of angled Tail sections anywhere across a full 360° - which can help achieve tidy routing of hoses.**

- 4.) Once sealant has cured\* fit hoses to tail sections after using hot water to soften.
- 5.) Apply twin hose clamps to each hose for secure connections to the tails.

\* Refer to manufacturer’s instructions for full cure time of sealant before fitting hoses.

### Part Numbers & Weight:

Model / Size	Weight	Part Number	Part Number PKG
T-Piece Connector 1½" BSP M-F-F	105 grams / 3.7 oz	90893	90894

Note: ‘PKG’ denotes packaged item supplied in bag with header card.

### Dimensions:

Dimensions are in millimetres  
All dimensions nominal

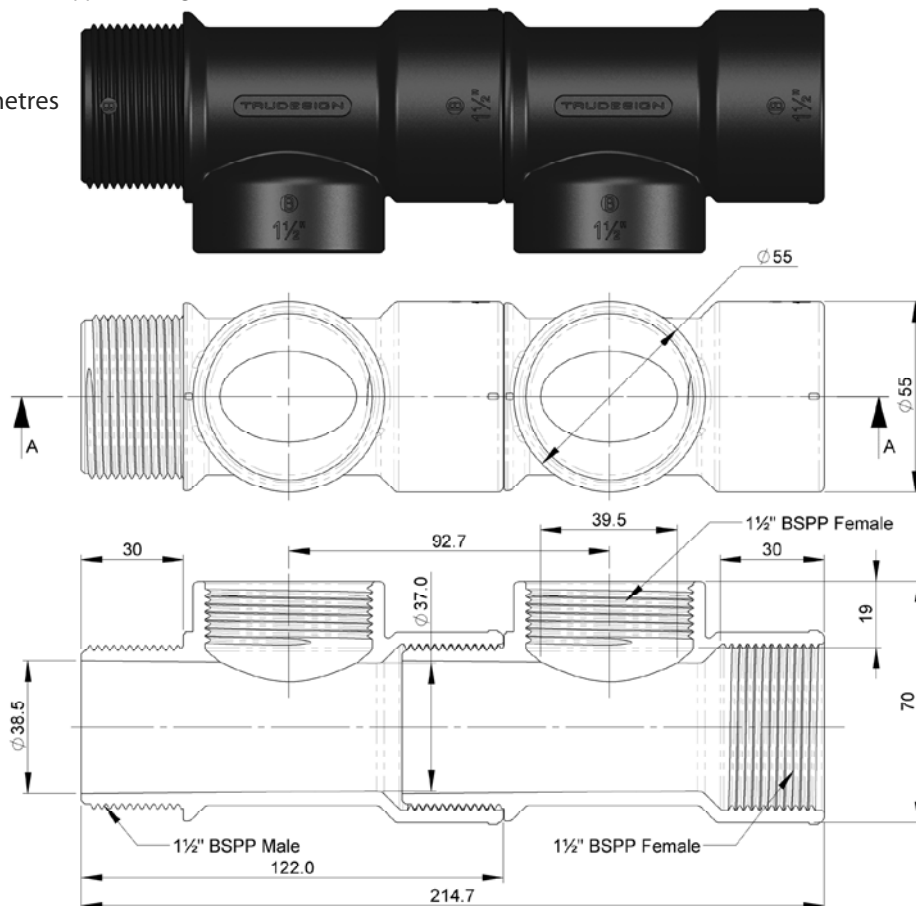

Page 4 of 4

